

# AHQB(X)24-1-100

On/Off, Non-Spring Return, Linear Stroke, 24 V



MFT



Technical Data	AHQB(X)24-1-100
Power supply	24 VAC $\pm$ 20% 50/60 Hz 24 VDC $\pm$ 20%
Power consumption	13 W (1.5 W)
Transformer sizing	23 VA (Class 2 power source)
Electrical connection	
AHQB24-1-100	3 ft [1m] 18 GA plenum rated cable protected NEMA 2 (IP54)
AHQX24-1-100	3 ft [1m] 10 ft [3m] 16 ft [5m] 18 GA plenum rated cable protected NEMA 2 (IP54)
Overload protection	electronic throughout full stroke
Control	on/off
Input impedance	1000 $\Omega$
Linear stroke	1.6" to 4.0" [40mm to 100 mm]
Linear force	44 lbf [200 Nm]
Stroke direction	reversible with $\downarrow/\uparrow$ switch
Manual override	external push button
Running time	7 seconds per 4" [100mm]
Humidity	5 to 95% RH non condensing (EN 60730-1)
Ambient temperature	-22°F to 122°F [-30°C to 50°C]
Storage temperature	-40°F to 176°F [-40°C to 80°C]
Housing	NEMA 2, IP54, UL enclosure type 2
Housing material	UL94-5VA
Agency listings	cULus acc. to UL 60730-1A/-2-14, CAN/CSA E60730-1:02, CE acc. to 2004/108/EEC and 2006/95/EC
Noise level (max)	<52 dB(A)
Servicing	maintenance free
Quality standard	ISO 9001
Weight	2.7 lbs [1.23 kg]

†Rated Impulse Voltage 800V, Type of action 1, Control Pollution Degree 3.

Linear Force min. 44 lbf for control of damper surfaces up to 12 sq. ft.

## Application

For On/Off control of dampers in HVAC systems. Actuator sizing should be done in accordance with the damper manufacturer's specifications.

## Operation

The actuator is not provided with and does not require and limit switches, but is electronically protected against overload. The anti-rotation strap supplied with the actuator will prevent lateral movement.

The AHQB(X) series provides 4" [100 mm] of linear stroke. The stroke of the gear rack can be adjusted on both sides in increments of 0.8" [20 mm] by means of the mechanical end stops.

When reaching the damper or actuator end position, the actuator automatically stops. The gears can be manually disengaged with a button on the actuator cover.

The AHQB(X)24-1-100 actuators use a sensorless brushless DC motor, which is controlled by an Application Specific Integrated Circuit (ASIC). The ASIC monitors and controls the actuator's rotation and provides a digital rotation sensing (DRS) function to prevent damage to the actuator in a stall condition. Power consumption is reduced in holding mode.

## Dimensions (Inches [mm])

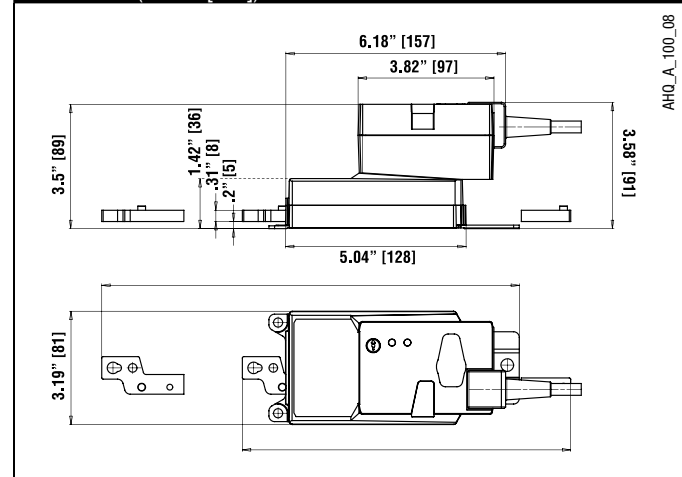

IM40024 - 05/10 - Subject to change. © Belimo Aircontrols (USA), Inc.

### Accessories

Z-DS1	Rotary Support to Compensate Lateral Forces
Z-KSC	Linear Coupling
P370	Shaft Mount Auxiliary Switch

**NOTE:** When using AHQB(X)24-1-100 actuators, only use accessories listed on this page.

### Typical Specification

On/Off control damper actuators shall be electronic type, with integrated linear stroking arm. Actuators shall have brushless DC motor technology and be protected from overload at all positions of linear stroke. Actuators shall have reversing switch and manual override on the cover. Run time shall be constant and independent of torque. Actuators shall be cUL listed, have a 5-year warranty, and be manufactured under ISO 9001 International Quality Control Standards. Actuators shall be as manufactured by Belimo.

### Wiring Diagram

#### ✂️ INSTALLATION NOTES

- 1 Provide overload protection and disconnect as required.
- 3 Actuators may also be powered by 24 VDC.

#### 📄 APPLICATION NOTES

- ◆ Meets cULus or UL and CSA Standard requirements without the need of an electrical ground connection.

#### ⚠️ **WARNING Live Electrical Components!**

During installation, testing, servicing and troubleshooting of this product, it may be necessary to work with live electrical components. Have a qualified licensed electrician or other individual who has been properly trained in handling live electrical components perform these tasks. Failure to follow all electrical safety precautions when exposed to live electrical components could result in death or serious injury.

