



Technical Data	BAE165 US
Rated voltage	24...240 VAC
Rated current	1 A
Connection	terminal strip
Operating temperature thermal trip	165°F (74°C)
Protection class	grounded enclosure
Ambient temperature	-22 °F to 122 °F [-30 to 50 °C]
Storage temperature	-40 °F to 122 °F [-40 to 50 °C]
Housing	NEMA 1, enclosure type 1
Agency listing	cULus listed according to: UL 873 and CSA C22.2 NO. 24-93
Servicing	maintenance free
Weight	0.88 lbs [0.4 kg]

WARNING- This device is intended for regulating applications only.

The BAE165 US is to be used as a primary sensor in UL555(S) Fire & Smoke applications only. It has been through a UL555S test and has passed for the application.

It is not to be used as a safety or high limit in any other application.

Application

The BAE165 US thermoelectric resettable tripping device operates in conjunction with a UL listed Belimo FSxx Series actuator for use in fire & smoke applications. The BAE drives a motorized fire damper to its safe position when the temperature at the damper (tripping temperature) exceeds 165°F. The device is connected in series with the power supply of the fire & smoke control actuator.

NOTE: The UL555(S) rating carried by the damper and the actuator is assigned as an assembly and can not be added in the field. The wiring method must be in accordance with Class 1 field wiring method as required by National Electrical Code (NEC_NFPA70). Use suitable UL or Canadian Certified wire. Jacket wires with suitable flexible conduit. Mount the flexible conduit into the BAE165 US metal bushing by means of the provided screw with a torque of 10.6 in-lb [1.2 Nm]. Properly terminate the conduit in a suitable junction box. Flexible conduit connection shall be grounded in order to maintain the proper basic insulation of the device.

Wiring

Use supply wires suitable for at least 75°C, copper (CU) conductor and wire size range (12-22) AWG, stranded. Apply terminal tightening torque of 5 in-lb.

Operation

The BAE165 US tripping device employs a thermal sensor switch that interrupts the supply power to the fire & smoke control actuator when the duct temperature exceeds 165°F. If the power supply is interrupted, the energy stored in the spring of the fire & smoke control actuator moves the damper back to its safe position.

The thermoelectric tripping device can be manually reset by gently pressing the reset button located on the box of the device after the temperature cooled down below the set point. After resetting, the BAE165 US will be operational again.

Caution: Before resetting, a careful inspection of the damper, damper actuator and the tripping device has to be made! Damage to the tripping device will result in loss of damper control!

Installation

The thermoelectric tripping device must be mounted on the duct or on the side of the damper by means of two mounting screws in such a manner, that there is an unobstructed flow of air to the thermal trip on the tip of the device. Device is intended to be installed with the sensing nose protruding into duct.

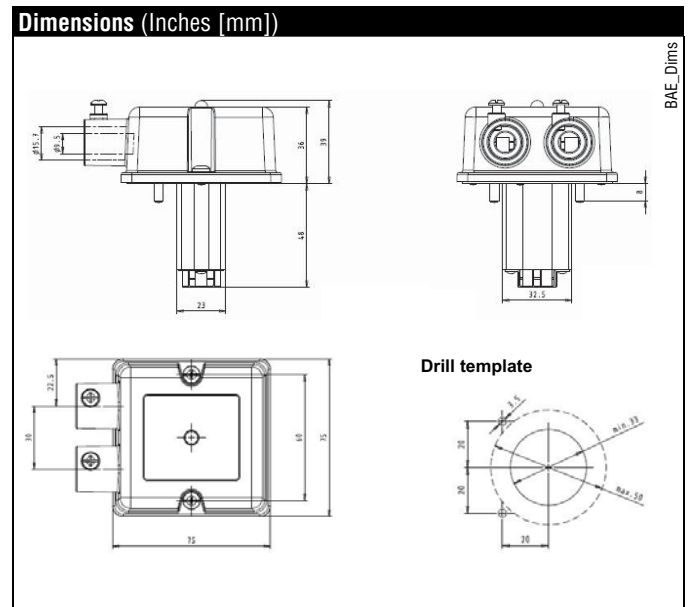

Wiring Diagrams

INSTALLATION NOTES

- 1 Provide overload protection and disconnect as required.
- 2 Actuators may be connected in parallel. Power consumption below 1 A must be observed.

APPLICATION NOTES

WARNING Live Electrical Components!
 During installation, testing, servicing and troubleshooting of this product, it may be necessary to work with live electrical components. Have a qualified licensed electrician or other individual who has been properly trained in handling live electrical components perform these tasks. Failure to follow all electrical safety precautions when exposed to live electrical components could result in death or serious injury.

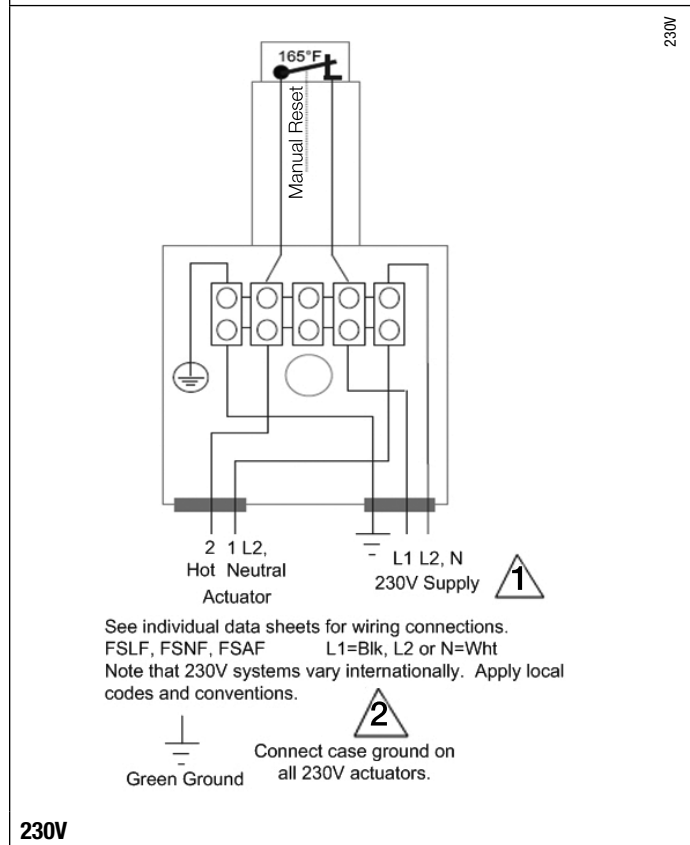
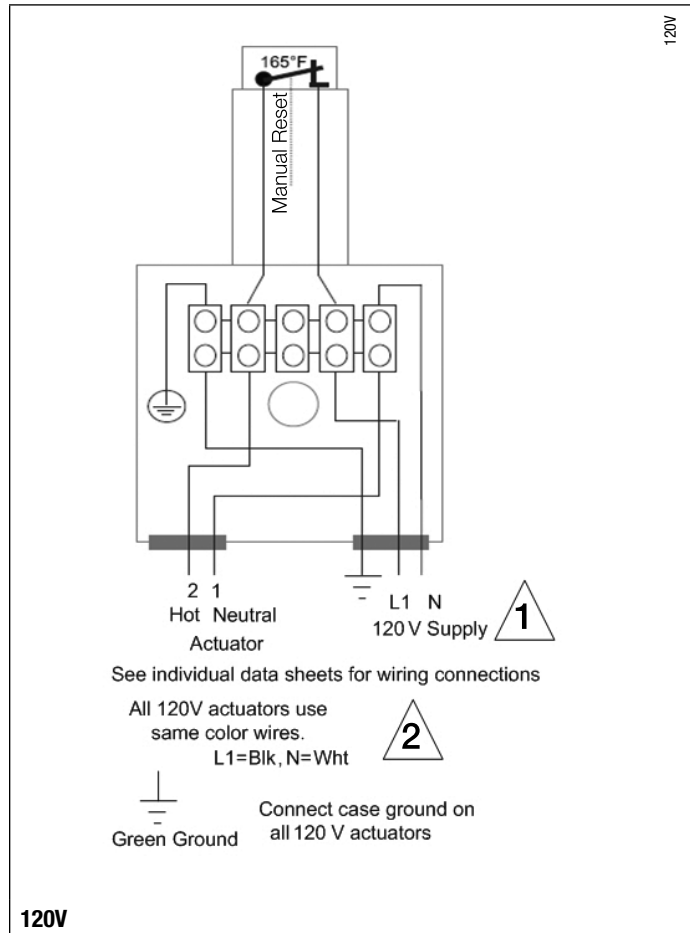
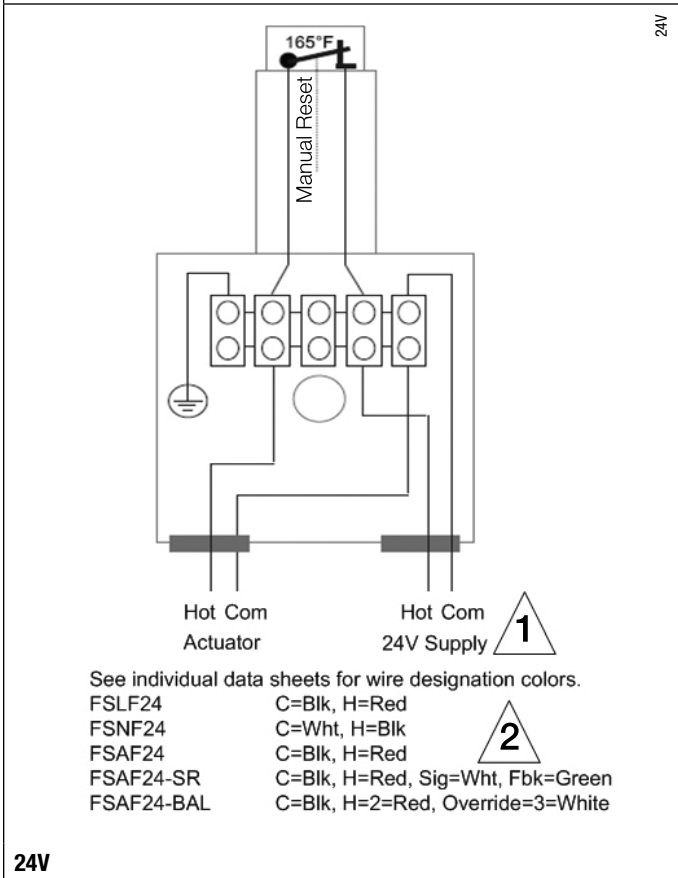
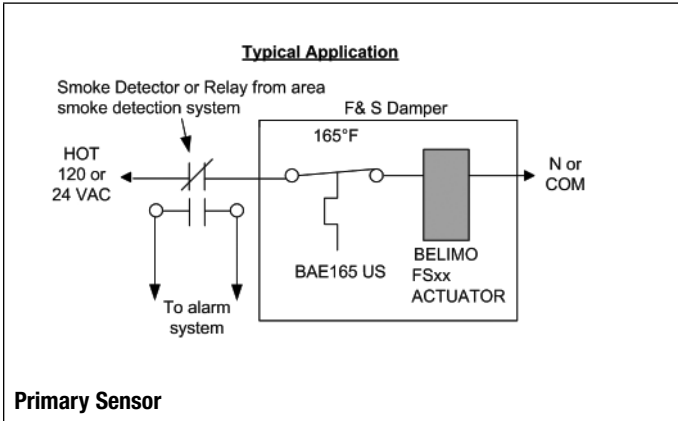

IM40044 - 05/10 - Subject to change. © Belimo Aircontrols (USA), Inc.