



MFT

### Technical Data

NFB24-MFT N4, NFB24-MFT-S N4, NFX24-MFT N4, NFX24-MFT-S N4	
Power supply	24 VAC ±20%, 50/60 Hz 24 VDC +20% / -10%
Power consumption	running 6.5 W
	holding 3 W
Transformer sizing	9 VA (class 2 power source)
Electrical connection NFB... N4	3 ft, 18 GA appliance cable, 1/2" conduit connector <b>-S models:</b> two 3 ft, 18 gauge appliance cables with 1/2" conduit connectors
	NFX... N4 3 ft [1m], 10 ft [3m] or 16 ft [5m] 18 GA appliance or plenum cables, with 1/2" conduit connector <b>-S models:</b> Two 3 ft [1m], 10 ft [3m] or 16 ft [5m] appliance cables with 1/2" conduit connectors
Overload protection	electronic throughout 0 to 95° rotation
Operating range Y*	2 to 10 VDC, 4 to 20mA (default) variable (VDC, PWM, floating point, on/off)
Input impedance	100 kΩ for 2 to 10 VDC (0.1 mA) 500 Ω for 4 to 20 mA 1500 Ω for PWM, floating point, on/off
Feedback output U*	2 to 10 VDC (max. 0.5 mA)
Torque	90 in-lb [10 Nm] minimum
Direction of rotation*	spring reversible with CW/CCW mounting inside housing motor reversible with built-in switch
Mechanical angle of rotation*	95° (adjustable with mechanical end stop, 35° to 95°)
Running time	spring < 20 sec @ -4°F to 122°F [-20°C to 50°C]; < 60 sec @ -22°F [-30°C]
	motor* 150 seconds (default), variable (40 to 220 secs)
Angle of Rotation Adaptation*	off (Default)
Override control*	min position = 0% mid. position = 50% max. position = 100%
Position indication	visual indicator, 0° to 95° (0° is full spring return position)
Manual override	5 mm hex crank (3/16" allen), supplied
Humidity	max. 95% RH non-condensing
Ambient temperature	-22°F to 122°F [-30°C to 50°C]
Storage temperature	-40°F to 176°F [-40°C to 80°C]
Housing	UL Type 4, NEMA 4, IP66
Housing material	polycarbonate
Agency listings†	cULus acc. to UL60730-1A/-2-14, CAN/CSA E60730-1:02, CE acc. to 2004/108/EC & 2006/95/EC
Noise level	≤40dB(A) motor @ 150 seconds, run time dependent ≤62dB(A) spring return
Servicing	maintenance free
Quality standard	ISO 9001
Weight	9.3 lbs (4.2 kg), 9.5 lbs (4.3 kg) with switches

\*Variable when configured with MFT options.

† Rated Impulse Voltage 800V, Type of action 1.AA (1.AA.B for -S version), Control Pollution Degree 4.

◆ Programmed for 40 sec motor run time. At 150 sec motor run time, transformer sizing is 6.5 VA and power consumption is 4.5 W running / 3 W holding.

### NFB24-MFT-S N4, NFX24-MFT-S N4

Auxiliary switches	2 x SPDT 3A (0.5A) @ 250 VAC, UL approved one set at +10°, one adjustable 10° to 90°
--------------------	--

- Torque min. 90 in-lb
- Control 2 to 10 VDC (DEFAULT)
- Feedback 2 to 10 VDC (DEFAULT)

### Application

For proportional modulation of dampers and control valves in HVAC systems. The NFB24-MFT N4 and NFX24-MFT N4 provides mechanical spring return operation for reliable fail-safe application.

### Default/Configuration

Default parameters for 2 to 10 VDC applications of the NFB24-MFT N4 and NFX24-MFT N4 actuator are assigned during manufacturing. If required, custom versions of the actuator can be ordered. The parameters noted in the Technical Data table are variable.

These parameters can be changed by three means:

- Pre-set configurations from Belimo
- Custom configurations from Belimo
- Configurations set by the customer using the MFT PC tool (version 3.4 or higher) software application.
- Handheld ZTH-GEN

### Operation

The NFB24-MFT N4, NFX24-MFT N4 actuator provides 95° of rotation and is provided with a graduated position indicator showing 0° to 95°. The actuator will synchronize the 0° mechanical stop or the damper or valves mechanical stop and use this point for its zero position during normal control operations.

The actuator uses a brushless DC motor which is controlled by an Application Specific Integrated Circuit (ASIC) and a microprocessor. The microprocessor provides the intelligence to the ASIC to provide a constant rotation rate and to know the actuator's exact position. The ASIC monitors and controls the brushless DC motor's rotation and provides a Digital Rotation Sensing (DRS) function to prevent damage to the actuator in a stall condition. The position feedback signal is generated with out the need for mechanical feedback potentiometers using DRS. The actuator may be stalled anywhere in its normal rotation without the need of mechanical end switches.

The NFB24-MFT N4, NFB24-MFT-S N4, NFX24-MFT N4 and NFX24-MFT-S N4 is mounted directly to control shafts up to 1.05" diameter by means of its universal clamp and anti-rotation bracket. A crank arm and several mounting brackets are available for damper applications where the actuator cannot be direct coupled to the damper shaft. The spring return system provides minimum specified torque to the application during a power interruption.

**NOTE:** Refer to Multi-Function Technology documentation.

### Dimensions (inches [mm])

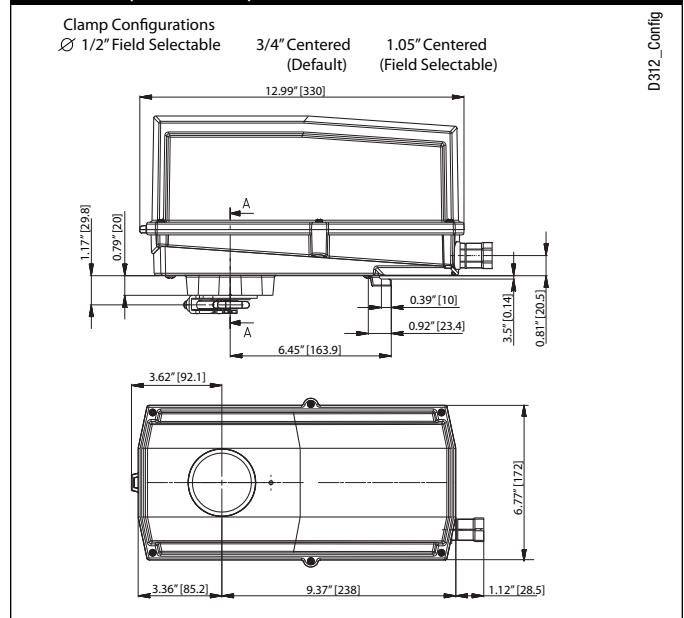

# NFB24-MFT N4, NFB24-MFT-S N4, NFX24-MFT N4, NFX24-MFT-S N4

NEMA 4, Proportional, Spring Return, Multi-Function Technology®



## Accessories

Tool-06	8mm and 10 mm wrench
43442-00001	Gland (needed for additional wires)
11097-00001	Gasket for Gland (needed for additional wires)

**NOTE:** When using NFB24-MFT N4, NFB24-MFT-S N4, NFX24-MFT N4, NFX24-MFT-S N4 actuators, only use accessories listed on this page.

For actuator wiring information and diagrams, refer to Belimo Wiring Guide.

## Typical Specification

Spring return control damper actuators shall be direct coupled type which require no crank arm and linkage and be capable of direct mounting to a jackshaft up to a 1.05" diameter. The actuator must provide proportional damper control in response to a 2 to 10 VDC or, with the addition of a 500Ω resistor, a 4 to 20 mA control input from an electronic controller or positioner. The actuators must be designed so that they may be used for either clockwise or counterclockwise fail-safe operation. Actuators shall use a brushless DC motor controlled by a microprocessor and be protected from overload at all angles of rotation. Run time shall be constant, and independent of torque. A 2 to 10 VDC feedback signal shall be provided for position feedback. Actuators shall be cULus Approved and have a 5 year warranty, and be manufactured under ISO 9001 International Quality Control Standards. Actuators shall be as manufactured by Belimo.

## Wiring Diagrams

### INSTALLATION NOTES

- 1 Provide overload protection and disconnect as required.
- 2 **CAUTION Equipment Damage!**  
Actuators may be connected in parallel if not mechanically mounted to the same shaft. Power consumption and input impedance must be observed.
- 3 Actuators may also be powered by 24 VDC.
- 4 Position feedback cannot be used with Triac sink controller. The actuator internal common reference is not compatible.
- 5 Control signal may be pulsed from either the Hot (source) or the Common (sink) 24 VAC line.
- 8 Contact closures A & B also can be triacs.  
A & B should both be closed for triac source and open for triac sink.
- 9 For triac sink the common connection from the actuator must be connected to the hot connection of the controller.

### APPLICATION NOTES

- ◆ Meets UL requirements without the need of an electrical ground connection.
- ◆ The ZG-R01 500 Ω resistor may be used.

**WARNING Live Electrical Components!**  
During installation, testing, servicing and troubleshooting of this product, it may be necessary to work with live electrical components. Have a qualified licensed electrician or other individual who has been properly trained in handling live electrical components perform these tasks. Failure to follow all electrical safety precautions when exposed to live electrical components could result in death or serious injury.

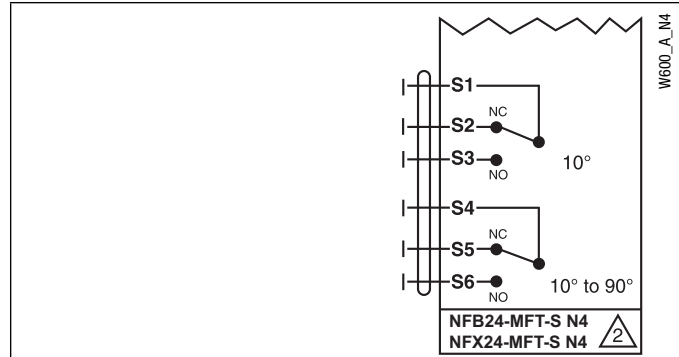

### Auxiliary Switches for NFB24-MFT-S N4, NFX24-MFT-S N4

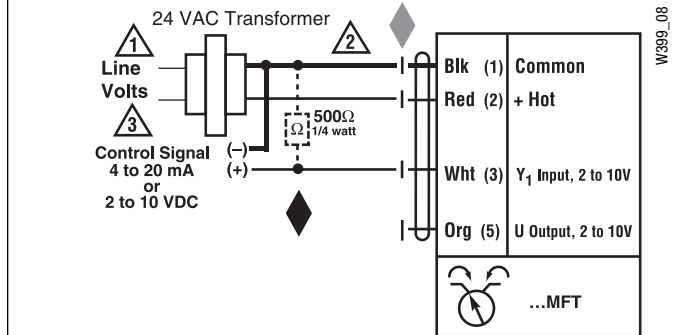

### VDC/4-20 mA

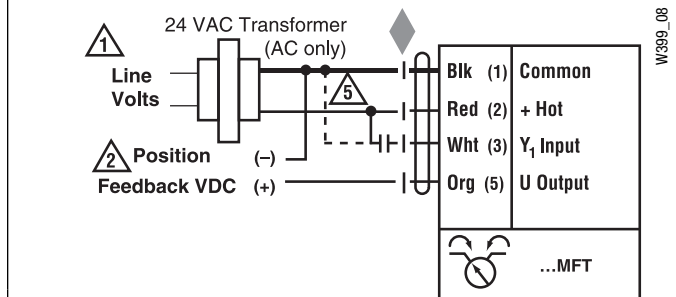

### PWM

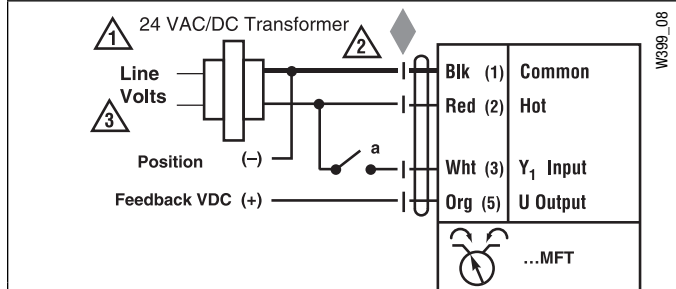

### On/Off control

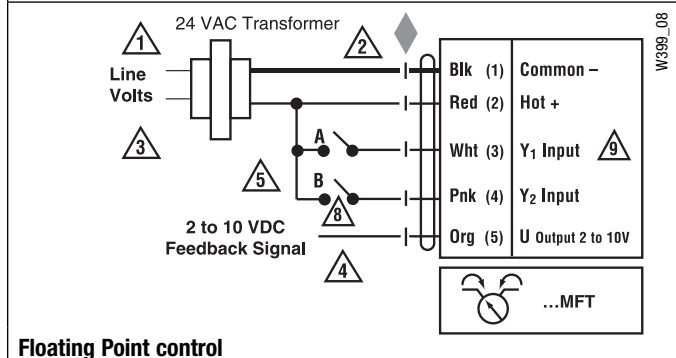

### Floating Point control