

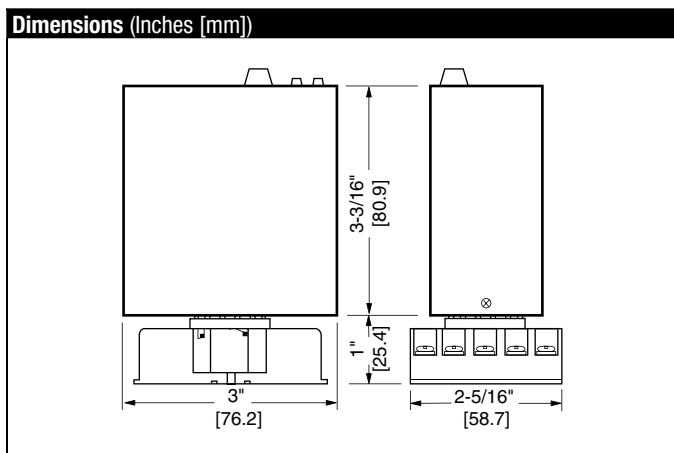

Technical Data	
Power supply	24 VAC $\pm$ 20% 50/60 Hz
Fusing	4A slow blow fuse
Power consumption	min. 5W (without actuator load)
Transformer	8 VA
Batteries	24 V Nominal 1.2 Ah (2-12 volt lead-acid batteries; batteries not supplied with module)
Maintenance	the batteries should be checked annually (approximate life is 6 years)
Charging circuit	charge current max. 150 mA charge voltage 24-27 V, temperature compensated
Battery back-up operation	24 V nominal 1.2 Ah, max. 60 W auto shut off after 250 seconds
Indication LED	green - main power source operation (battery will be charged) red - battery back-up operation
Mounting	mounted in the control panel with an 11 terminal plug-in base (not supplied with module)
Ambient temperature	14°F to 122°F [-10°C ... 50°C]



## Application

Several Belimo damper actuators can be used either with 24 VAC or 24 VDC.

In case of a power failure, the NSV24 battery back-up unit switches the damper actuator from its main AC power supply over to the 24 VDC battery to drive the actuators to their safety position.

For easy maintenance, the battery back-up system is placed in the control panel, not in the actuator. Several actuators may be powered by one back-up module. The batteries are separate from the NSV24.

## Operation

The NSV24 is connected to the same 24 VAC power source as the damper actuators. It also charges the 24 V (2-12 volt batteries) storage battery. Its charge current is limited to 150 mA maximum, and the maximum charge voltage is temperature compensated.

In case of a power failure, the NSV24 switches immediately over to the battery power source, and according to the control function, the actuators will move to their safety position. After 250 seconds, the batteries are disconnected from the actuators to prolong battery life. Because of this, a safe battery back-up can be provided for several short-term failures. The main power source operation is indicated by a green LED, and the battery power source by a red LED.

Connectable Actuator Models	Maximum per module
GMB24-3X1	20
GMX24-3	15
GMX24-MFTX1	15
GMB24-SR	15
AMB24-3	30
AMX24-MFT	30
AMB24-SR	30
NMB24-3	30
NMX24-MFT	30
NMB24-SR	30
LMB24-3	30
LMX24-MFT	30
LMB24-SR	30

## Accessories

**NSV-BAT** 12 VDC 1.2 Ah battery (2 required)

