

# B3 Series, Three Way, Characterized Control Valve Stainless Steel Ball and Stem



Technical Data	
Service	chilled or hot water, 60% glycol
Flow characteristic	A-port equal percentage B-port modified for constant common port flow
Action	90° rotation
Sizes	½", ¾", 1", 1¼", 1½", 2"
Type of end fitting	NPT female ends
Materials:	
Body	forged brass, nickel plated
Ball	stainless steel
Stem	stainless steel
Seats	PTFE
Characterizing disc	Tefzel®
Packing	2 EPDM O-rings, lubricated
Body pressure rating	
600 psi	½" - 1"
400 psi	1¼" - 2"
Media temp. range	0°F to 212°F [-18°C to 100°C]
Close off pressure	
200 psi	½" - 2"
Maximum differential pressure (ΔP)	30 psi for typical applications
Leakage	0% for A to AB <2.0% for B to AB
External leakage	according to EN 12266-1:2003
C <sub>v</sub> rating	A-port: see product chart for values B-port: 70% of A to AB C <sub>v</sub>

Tefzel® is a registered trademark of DuPont

## Dimensions

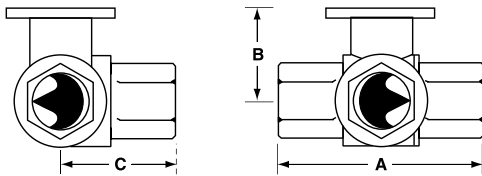

3Way Valve-B307-B320

Valve Body	Valve Nominal Size		Dimensions (Inches [mm])		
	Inches	DN [mm]	A	B	C
B307-B311	½"	15	2.41" [61.1]	1.39" [35.2]	1.20" [30.6]
B312-B315	½"	15	2.38" [60.4]	1.78" [45.2]	1.29" [32.8]
B317-B320	¾"	20	2.73" [69.3]	1.87" [47.4]	1.47" [37.3]
B322-B325	1"	25	3.09" [78.4]	1.87" [47.4]	1.59" [40.3]
B329-B331	1¼"	32	3.96" [100.6]	2.27" [57.7]	2.14" [54.3]
B338-B341	1½"	40	4.39" [111.6]	2.51" [63.7]	2.40" [61.1]
B347-B352	2"	50	4.90" [124.5]	2.73" [69.5]	2.74" [69.7]

## Application

This valve is typically used in air handling units on heating or cooling coils, and fan coil unit heating or cooling coils. Some other common applications include Unit Ventilators, VAV box re-heat coils and bypass loops. This valve is suitable for use in a hydronic system with variable or constant flow.

C <sub>v</sub>	Valve Nominal Size		Type	Suitable Actuators		
	Inches	DN [mm]	3-Way NPT	Non-Spring	Spring	
0.3	½"	15	B307	TR Series	LR Series	NR...M4 Series
0.46	½"	15	B308			
0.8	½"	15	B309			
1.2	½"	15	B310			
1.9	½"	15	B311			
3	½"	15	B312			
4.7	½"	15	B313			
10	½"	15	B315*			
4.7	¾"	20	B317			
7.4	¾"	20	B318			
24	¾"	20	B320*	TF Series	LF Series	
7.4	1"	25	B322			
10	1"	25	B323			
30	1"	25	B325*			
10	1¼"	32	B329			
19	1¼"	32	B330			
25	1¼"	32	B331			
19	1½"	40	B338			
29	1½"	40	B339			
37	1½"	40	B340			
46	1½"	40	B341	AR Series	AR...M4 Series	
29	2"	50	B347			
37	2"	50	B348			
46	2"	50	B349			
57	2"	50	B350			
68	2"	50	B351			
83	2"	50	B352			

\*Models without characterizing disc

## Flow Patterns

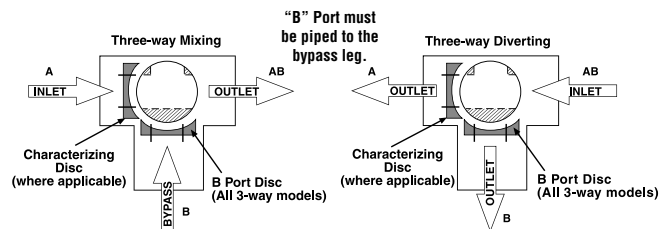

IM40013 - 06/11 - Subject to change. © Belimo Aircontrols (USA), Inc.

# LF24-MFT Actuators, Multi-Function Technology



MFT



## Models

LF24-MFT US  
LF24-MFT-S US w/built-in Aux. Switch

Technical Data		
Control		MFT
Control signal		2 to 10 VDC
Power consumption	running	2.5 W
	holding	1 W
Transformer sizing		5 VA (class 2 power source)
Electrical connection		½" conduit connector
	(-S models have 2 cables)	3 ft [1m], 18 GA appliance cable
Overload protection		electronic throughout 0° to 95° rotation
Feedback output		2 to 10 VDC, 0.5 mA max
Input impedance		100 kΩ for 2 to 10 VDC (0.1 mA)
		500 Ω for 4 to 20mA
		750 Ω for PWM
		500 Ω for on/off and floating point
Angle of rotation		95°
Direction of rotation	spring	reversible with CW/CCW mounting
	motor	reversible with built-in  switch
Position indication		visual indicator
Running time	motor	150 seconds independent of load (proportional, default)
	spring	<25 seconds @ -4°F to 122°F [-20°C to 50°C] <60 seconds @ -22°F [-30°C]
Ambient temperature		-22° F to 122° F [-30° C to 50° C]
Housing		NEMA 2
Agency listings		cULus according to UL 873 and CAN/CSA C22.2 No. 24-93
Noise level (max)	running	<30 db(A)
	spring return	62 db(A)
Quality standard		ISO 9001

LF24-MFT-S US		
Auxiliary switch		1 x SPDT, 6A (1.5A) @ 250 VAC, UL Listed, adjustable 0° to 95° (double insulated)

## Dimensions with 2-Way Valve

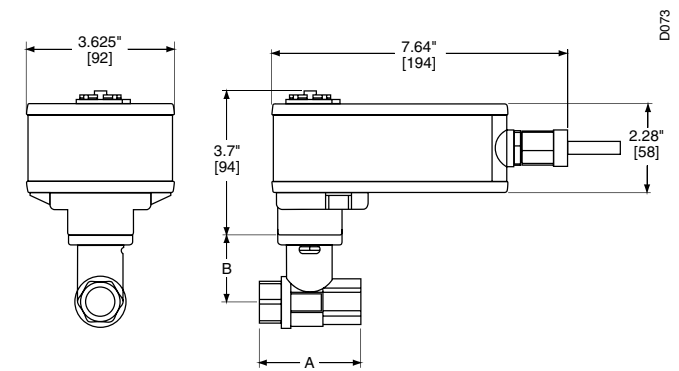

Valve Body	Valve Nominal Size		Dimensions (Inches [mm])	
	Inches	DN [mm]	A	B
B207-B211	½"	15	2.41" [61.1]	1.39" [35.2]
B212-B215	½"	15	2.38" [60.4]	1.78" [45.2]
B217-B220	¾"	20	2.73" [69.3]	1.87" [47.4]
B222-B225	1"	25	3.09" [78.4]	1.87" [47.4]
B229-B230	1¼"	32	3.72" [94.6]	1.87" [47.4]

## Dimensions with 3-Way Valve

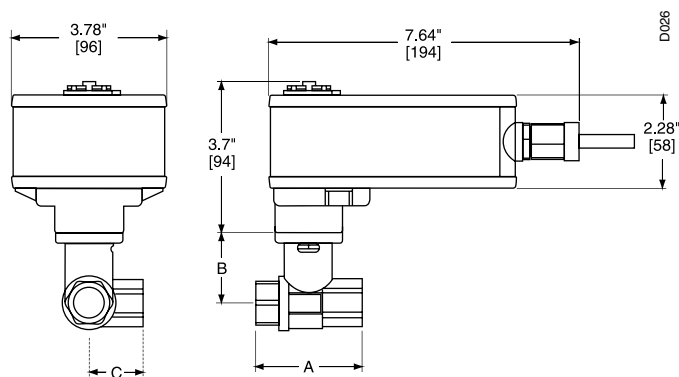

Valve Body	Valve Nominal Size		Dimensions (Inches [mm])		
	Inches	DN [mm]	A	B	C
B307-B311	½"	15	2.41" [61.1]	1.39" [35.2]	1.20" [30.6]
B312-B315	½"	15	2.38" [60.4]	1.78" [45.2]	1.29" [32.8]
B317-B320	¾"	20	2.73" [69.3]	1.87" [47.4]	1.47" [37.3]
B322-B325	1"	25	3.09" [78.4]	1.87" [47.4]	1.59" [40.3]

M40013 - 06/11 - Subject to change. © Belimo Aircontrols (USA), Inc.

### Wiring Diagrams

#### ✂️ INSTALLATION NOTES

- ⚠️ **CAUTION Equipment damage!**  
Actuators may be connected in parallel if not mechanically mounted to the same shaft. Power consumption and input impedance must be observed.
- ⚠️ Actuators may also be powered by 24 VDC.
- ⚠️ IN4004 or IN4007 diode (IN4007 supplied, Belimo part number 40155).
- ⚠️ Triac A and B can also be contact closures.
- ⚠️ Control signal may be pulsed from either the Hot (Source) or Common (Sink) 24 VAC line.
- ⚠️ Position feedback cannot be used with Triac sink controller. The actuators internal common reference is not compatible.

#### 📄 APPLICATION NOTES

- ◆ The ZG-R01 500 Ω resistor converts the 4 to 20 mA control signal to 2 to 10 VDC, up to 2 actuators may be connected in parallel.

⚠️ **WARNING Live Electrical Components!**  
During installation, testing, servicing and troubleshooting of this product, it may be necessary to work with live electrical components. Have a qualified licensed electrician or other individual who has been properly trained in handling live electrical components perform these tasks. Failure to follow all electrical safety precautions when exposed to live electrical components could result in death or serious injury.

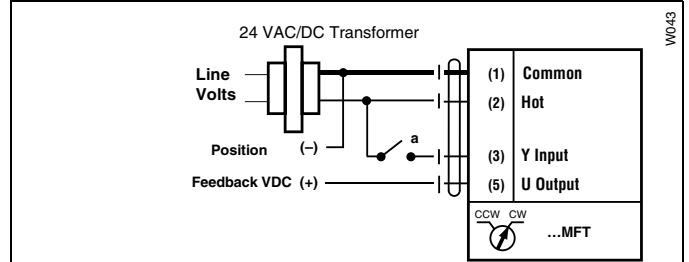

On/Off control

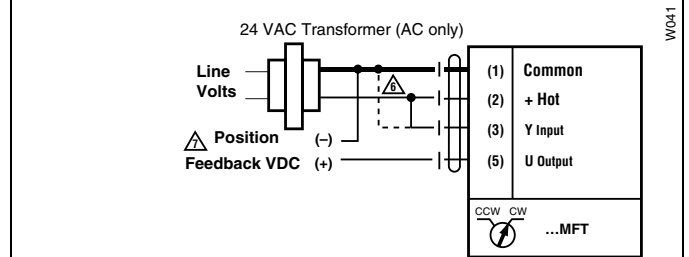

PWM, triac source and sink

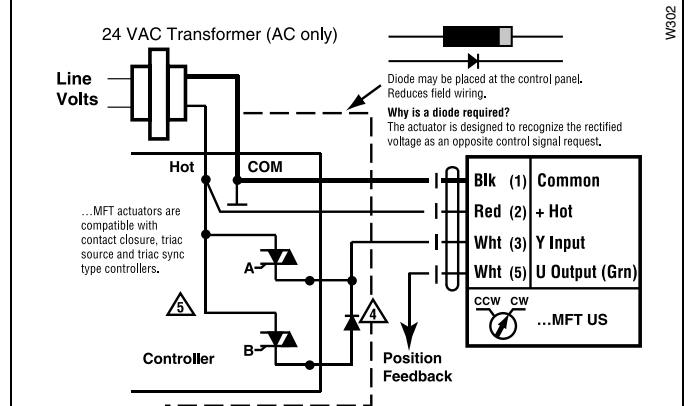

Floating Point control

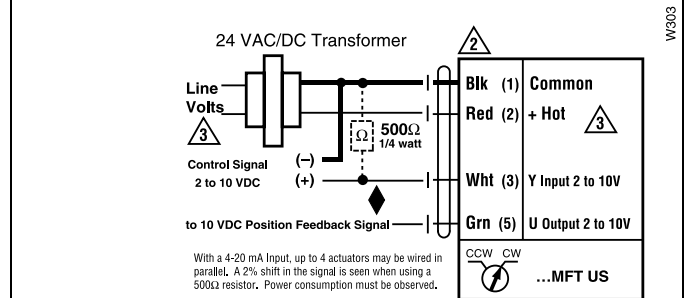

Proportional 2 to 10 or 4 to 20 mA control signal