

B3 Series, Three Way, Characterized Control Valve Stainless Steel Ball and Stem



Technical Data	
Service	chilled or hot water, 60% glycol
Flow characteristic	A-port equal percentage B-port modified for constant common port flow
Action	90° rotation
Sizes	½", ¾", 1", 1¼", 1½", 2"
Type of end fitting	NPT female ends
Materials:	
Body	forged brass, nickel plated
Ball	stainless steel
Stem	stainless steel
Seats	PTFE
Characterizing disc	Tefzel®
Packing	2 EPDM O-rings, lubricated
Body pressure rating	
600 psi	½" - 1"
400 psi	1¼" - 2"
Media temp. range	0°F to 212°F [-18°C to 100°C]
Close off pressure	
200 psi	½" - 2"
Maximum differential pressure (ΔP)	30 psi for typical applications
Leakage	0% for A to AB <2.0% for B to AB
External leakage	according to EN 12266-1:2003
C _v rating	A-port: see product chart for values B-port: 70% of A to AB C _v

Tefzel® is a registered trademark of DuPont

Dimensions

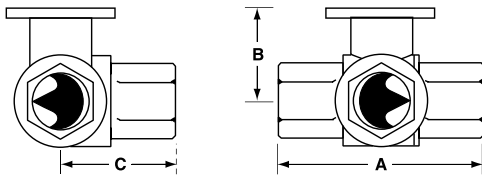

3Way Valve-B307-B320

Valve Body	Valve Nominal Size		Dimensions (Inches [mm])		
	Inches	DN [mm]	A	B	C
B307-B311	½"	15	2.41" [61.1]	1.39" [35.2]	1.20" [30.6]
B312-B315	½"	15	2.38" [60.4]	1.78" [45.2]	1.29" [32.8]
B317-B320	¾"	20	2.73" [69.3]	1.87" [47.4]	1.47" [37.3]
B322-B325	1"	25	3.09" [78.4]	1.87" [47.4]	1.59" [40.3]
B329-B331	1¼"	32	3.96" [100.6]	2.27" [57.7]	2.14" [54.3]
B338-B341	1½"	40	4.39" [111.6]	2.51" [63.7]	2.40" [61.1]
B347-B352	2"	50	4.90" [124.5]	2.73" [69.5]	2.74" [69.7]

Application

This valve is typically used in air handling units on heating or cooling coils, and fan coil unit heating or cooling coils. Some other common applications include Unit Ventilators, VAV box re-heat coils and bypass loops. This valve is suitable for use in a hydronic system with variable or constant flow.

C _v	Valve Nominal Size		Type	Suitable Actuators		
	Inches	DN [mm]	3-Way NPT	Non-Spring	Spring	
0.3	½"	15	B307	TR Series	LR Series	NR...M4 Series
0.46	½"	15	B308			
0.8	½"	15	B309			
1.2	½"	15	B310			
1.9	½"	15	B311			
3	½"	15	B312			
4.7	½"	15	B313			
10	½"	15	B315*			
4.7	¾"	20	B317			
7.4	¾"	20	B318			
24	¾"	20	B320*	TF Series	LF Series	
7.4	1"	25	B322			
10	1"	25	B323			
30	1"	25	B325*			
10	1¼"	32	B329			
19	1¼"	32	B330			
25	1¼"	32	B331			
19	1½"	40	B338			
29	1½"	40	B339			
37	1½"	40	B340			
46	1½"	40	B341	AR Series	AR...M4 Series	
29	2"	50	B347			
37	2"	50	B348			
46	2"	50	B349			
57	2"	50	B350			
68	2"	50	B351			
83	2"	50	B352			

*Models without characterizing disc

Flow Patterns

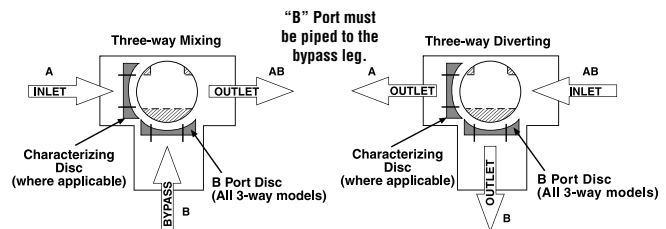

IM40013 - 06/11 - Subject to change. © Belimo Aircontrols (USA), Inc.

TR24-3 Actuators, On-Off, Floating Point



Models

TR24-3-T US	
TR24-3 US	TR24-3-T US with 3 ft plenum rated cable
TR24-3/300 US	TR24-3-T US with 10 ft plenum rated cable
TR24-3/500 US	TR24-3-T US with 16 ft plenum rated cable

Technical Data

Control	on/off, floating point
Nominal voltage	24 VAC 50/60 Hz
Nominal voltage range	19.2...28.8 VAC
Power consumption	1 W
Transformer sizing	1VA (class 2 power source)
Electrical connection	screw terminals accessible after removal of small cover (3 ft, 10 ft, 16 ft cables optional)
Input impedance	0.36 kΩ
Angle of rotation	90°
Position indication	integrated into handle
Manual override	push down handle
Running time	90 seconds @ 60 hz, 108 seconds @ 50 hz
Humidity	5 to 95% non-condensing
Ambient temperature	-22°F to 122°F (-30°C to 50°C)
Storage temperature	-40°F to 176°F (-40°C to 80°C)
Housing	NEMA 1/IP40
Housing rating	UL94-5V(B)
Agency listing†	cULus according to UL 60730-1A/-2-14, CAN/CSA E60730-1:02, CE according to 2004/108/EC and 2006/95/EC for line voltage and/or -S versions
Noise level	max. 35 db (A)
Quality standard	ISO 9001

† Rated impulse voltage 330V, Control pollution degree 2, Type of action 1

Dimensions with 2-Way Valve

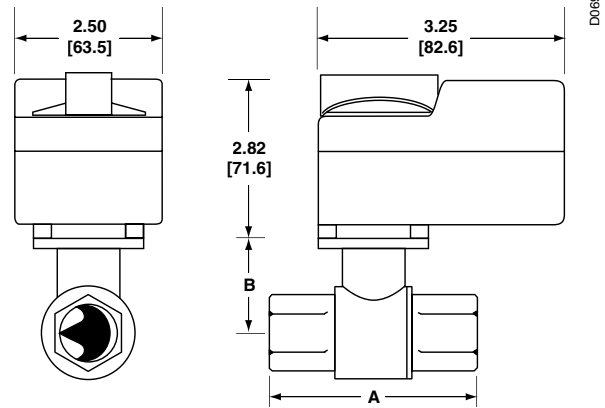

Valve Body	Valve Nominal Size		Dimensions (Inches [mm])	
	Inches	DN [mm]	A	B
B207(B)-B211(B)	½"	15	2.41" [61.1]	1.39" [35.2]
B212(B)-B215(B)	½"	15	2.38" [60.4]	1.78" [45.2]
B217(B)-B220(B)	¾"	20	2.73" [69.3]	1.87" [47.4]

Dimensions with 3-Way Valve

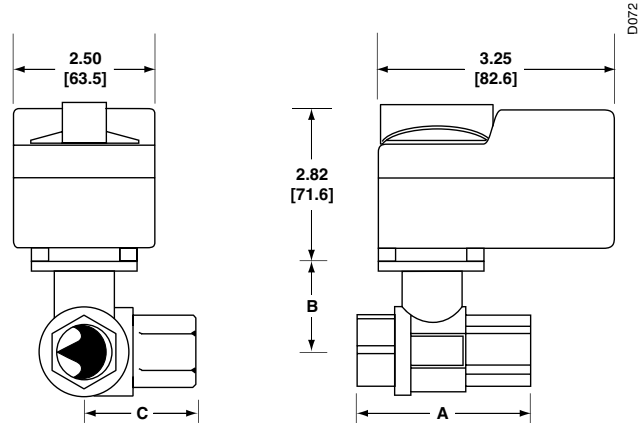

Valve Body	Valve Nominal Size		Dimensions (Inches [mm])		
	Inches	DN [mm]	A	B	C
B307(B)-B311(B)	½"	15	2.41" [61.1]	1.39" [35.2]	1.20" [30.6]
B312(B)-B315(B)	½"	15	2.38" [60.4]	1.78" [45.2]	1.29" [32.8]
B317(B)-B320(B)	¾"	20	2.73" [69.3]	1.87" [47.4]	1.47" [37.3]

M40013 - 06/11 - Subject to change. © Belimo Aircontrols (USA), Inc.

Wiring Diagrams

✂ INSTALLATION NOTES

- 2 The common connection from the actuator must be connected to the Hot connection of the controller.
- 3 Actuators with plenum rated cable do not have numbers on wires; use color codes instead.
- 4 The actuator Hot must be connected to the control board Hot.

⚠ WARNING Live Electrical Components!
 During installation, testing, servicing and troubleshooting of this product, it may be necessary to work with live electrical components. Have a qualified licensed electrician or other individual who has been properly trained in handling live electrical components perform these tasks. Failure to follow all electrical safety precautions when exposed to live electrical components could result in death or serious injury.

NOTE: TR24-3(-T) US cannot be wired in parallel with themselves or any other actuator.

