

B3...VS Series, 3-Way, Ball Valve Bronze Body, Stainless Steel Ball and Stem



- 316 Stainless Ball and Stem
- Reinforced PTFE seats and stuffing box
- Blow-out proof stem design
- Adjustable packing gland

Application

These threaded valves are designed to provide modulating or two position control of hot or chilled water.

Typical applications include reheat coils, VAV terminal control, unit ventilators, and air handlers, especially in areas which have minimum profile requirements.

- 400 PSIG WOG, Cold Non-Shock

Technical Data	
Media	chilled or hot water, glycol
Flow characteristic	modified equal percentage
Action	90° rotation A to AB open CCW, B to AB open CW
Sizes	½", ¾", 1", 1¼", 1½", 2"
Type of end fitting	SAE NPT (female connection)
Materials:	
1 Stem Packing	PTFE
2 Stem Bearing	PTFE
3 Ball	316 Stainless Steel
4 Seat (x2)	PTFE w/ Durafill
5 Retainer	B16 (½" - 1") Brass B584 (1¼" - 2") Brass
6 Gland	ASTM B16 Brass
7 Stem	316 Stainless steel
8 Jam Nut	PTFE (1¼" - 2")
9 Body Seal	B584-C84400 Bronze

C _v	Valve Nominal Size		Type	Suitable Return Actuators		
	Inches	DN (mm)		Spring		Non-Spring
4.8	½	15	B315VS	LF	NF	LM
11	¾	20	B320VS	NF		NM Series
21	1	25	B325VS	AF Series		
33	1¼	32	B332VS			AM
49	1½	40	B340VS			GM Series
91	2	50	B350VS			

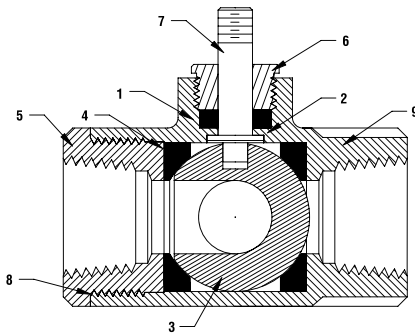

Pressure rating	400 psig WOG
Media temp. range	-22°F to 250°F (-30°C to 120°C)
Close-off pressure	400 psig @ 100°F
Maximum differential pressure (ΔP)	<75 psig

Flow Patterns

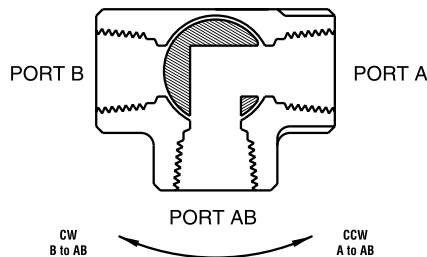

IM40006 - 05/10 - Subject to change. © Belimo Aircontrols (USA), Inc.

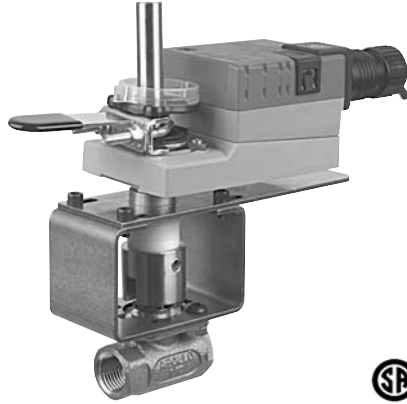

Models

AMX24-MFT-X1
AMX24-MFT95-X1

Technical Data	
Power supply	24 VAC ± 20% 50/60 Hz 24 VDC ± 10%
Power consumption	4 W (1.25 W)
Transformer sizing	6 VA (class 2 power source)
Electrical connection	3 ft [1m] 10 ft [3m] 16 ft [5m] 18 GA plenum rated cable ½" conduit connector
Overload protection	electronic throughout 0° to 95° rotation
Input impedance	100 kΩ for 2 to 10 VDC (0.1 mA) 500 Ω for 4 to 20 mA 750 Ω for PWM 1500 Ω for on/off and floating point
Feedback	2 to 10 VDC, 0.5 mA max VDC variable
Angle of rotation	max 95°, adjustable with mechanical stop electronically variable
Torque	180 in-lb [20 Nm]
Direction of rotation	reversible with switch
Position indication	reflective visual indicator (snap-on)
Manual override	external push button
Running time	150 seconds (default) variable (90 to 350 seconds)
Humidity	5 to 95% RH non-condensing (EN 60730-1)
Ambient temperature	-22° F to 122° F [-30° C to 50° C]
Storage temperature	-40° F to 176° F [-40° C to 80° C]
Housing	NEMA type 2/IP54
Housing material	UL94-5VA
Agency listings	cULus according to UL 60730-1/-2-14, CAN/CSA E60730-1, CSA C22.2 No. 24-93, CE according to 89/336/EEC
Noise level	<45 db(A)
Servicing	maintenance free
Quality standard	ISO 9001

Dimensions with 2-Way Valve

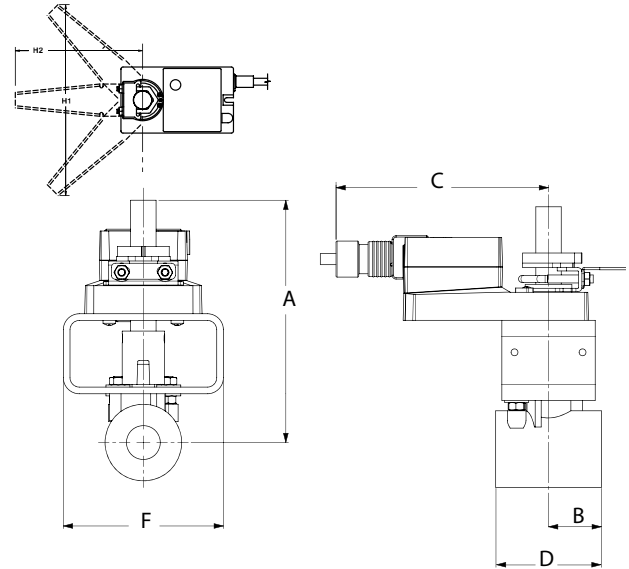

PAGE7, D308

Valve Nominal Size

Valve Body	COP	Inches	DN [mm]	A	B	C	D	F	H1	H2
B2100VS-68	400	1	25	8.00	2.00	4.62	3.60	4.60	9.75	8.50
B2125VS-48	400	1¼	32	8.00	2.00	4.62	4.00	4.60	9.75	8.50
B2150VS-84	400	1½	40	8.00	2.00	4.62	4.40	4.60	9.75	8.50
B2200VS-108	400	2	50	8.00	2.00	4.62	4.70	4.60	9.75	8.50
B2125VSS-48	1000	1¼	32	8.00	2.00	4.62	4.00	4.60	9.75	8.50
B2150VSS-84	1000	1½	40	8.00	2.00	4.62	4.40	4.60	9.75	8.50
B2200VSS-108	1000	2	50	8.00	2.00	4.62	5.50	5.43	9.75	8.50

Dimensions (Inches)

Dimensions with 3-Way Valve

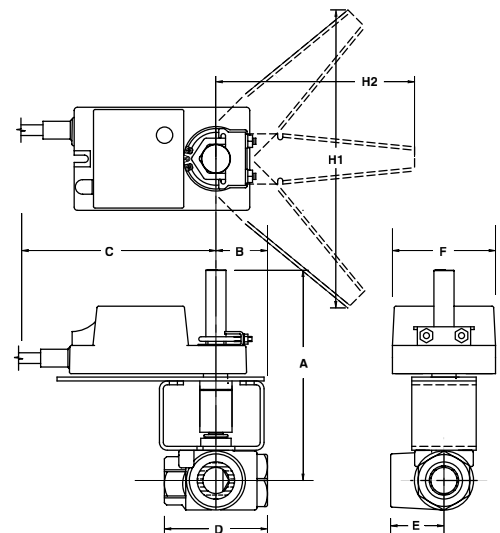

PAGE11

Valve Nominal Size

Valve Body	COP	Inches	DN [mm]	A	B	C	D	E	F	H1	H2
B320VS	75	¾	20	6.70	1.50	6.88	2.82	1.62	3.15	9.75	8.50
B325VS	75	1	25	7.00	1.50	6.88	3.56	1.88	3.15	9.75	8.50
B332VS	75	1¼	32	7.00	2.00	7.48	4.13	2.07	3.46	9.75	8.50

Dimensions (Inches)

Wiring Diagrams

- 1 Provide overload protection and disconnect as required.
- 3 Actuators may also be powered by 24 VDC.
- 4 Position feedback cannot be used with Triac sink controller. The actuator internal common reference is not compatible.
- 5 Control signal may be pulsed from either the Hot (source) or the Common (sink) 24 VAC line.
- 6 ZG-R01 may be used.
- 7 Contact closures A & B also can be triacs. A & B should both be closed for triac source and open for triac sink.
- 8 For triac sink the common connection from the actuator must be connected to the hot connection of the controller.

APPLICATION NOTES

- Meets cULus or UL and CSA requirements without the need of an electrical ground connection.

WARNING Live Electrical Components! During installation, testing, servicing and troubleshooting of this product, it may be necessary to work with live electrical components. Have a qualified licensed electrician or other individual who has been properly trained in handling live electrical components perform these tasks. Failure to follow all electrical safety precautions when exposed to live electrical components could result in death or serious injury.

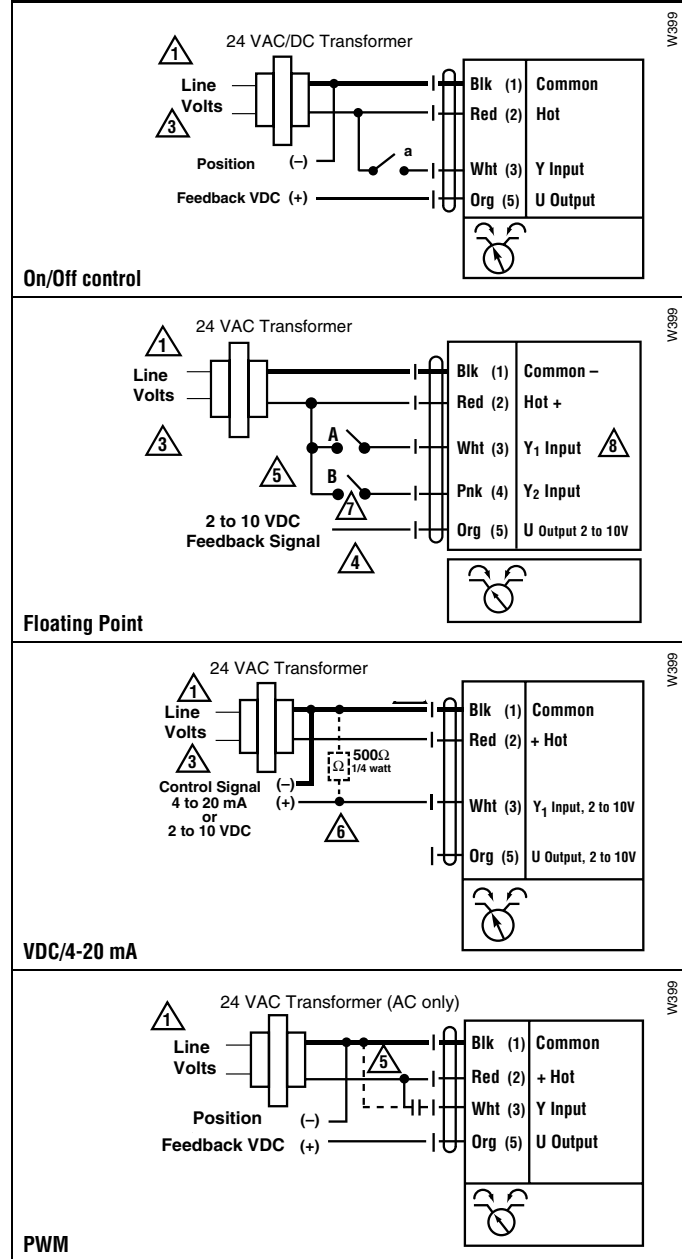



INSTALLATION NOTES

- △21 Provide overload protection and disconnect as required.
- △22 Actuators and controller must have separate transformers.
- △23 Consult controller instruction data for more detailed information.
- △24 Resistor value depends on the type of controller and the number of actuators. No resistor is used for one actuator. Honeywell® resistor kits may also be used.
- △25 To reverse control rotation, use the reversing switch.

Override

Switch A	Switch B	Damper Position
		Damper Open
		Damper Closed

The direction of rotation switch is set so that the fail safe position and the position of the damper is closed with no signal at wire R.

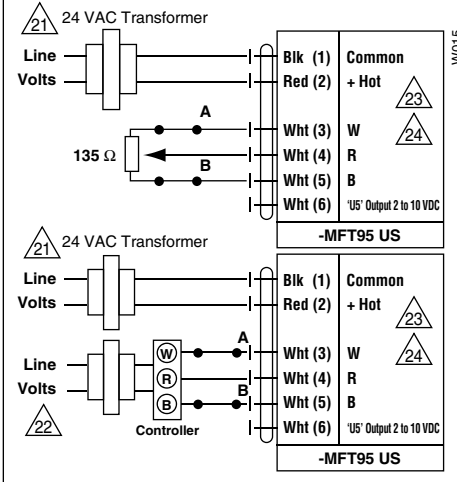

Low Limit Control

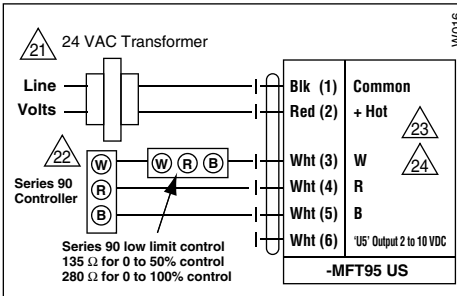

High Limit Control

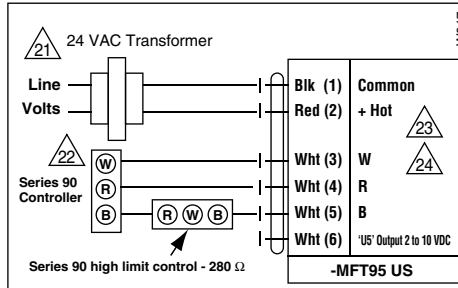

Wiring Multiple Actuators to a Series 90 Controller

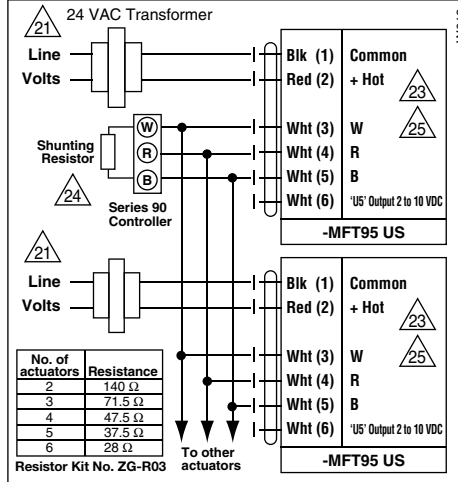

Wiring Multiple Actuators to a Series 90 Controller using a Minimum Position Potentiometer

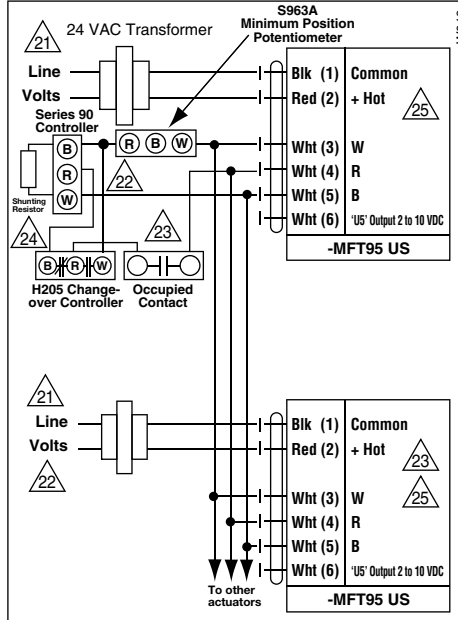

Typical wiring diagrams for multiple actuators used with the W973, W7100 and T775 controllers

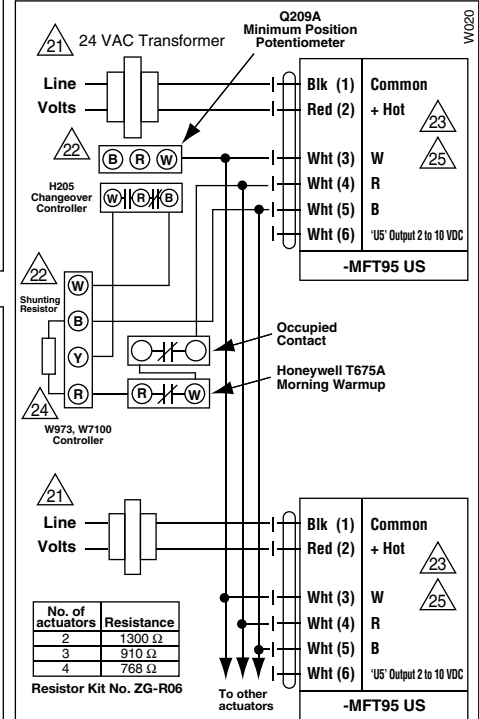

Used with the W973 and W7100 controllers

