



Application

This valve is typically used in air handling units on heating or cooling coils, and fan coil unit heating or cooling coils. Some other common applications include Unit Ventilators, VAV box re-heat coils and bypass loops. This valve is suitable for use in a hydronic system with variable or constant flow.

Technical Data	
Service	chilled or hot water, 60% glycol
Flow characteristic	A-port equal percentage
Action	90° rotation
Sizes	2½", 3", 4", 5", 6"
Type of end fitting	pattern to mate with ANSI 125 flange
Materials:	
Body	cast iron - GG25
Ball	stainless steel
Stem	stainless steel
Seats	PTFE
Characterizing disc	stainless steel
Packing	2 EPDM O rings, lubricated
Body pressure rating	according to ANSI 125, standard class B
Media temp. range	0°F to 248°F [-18°C to +120°C]
Close off pressure	100 psi
Maximum differential pressure (ΔP)	50 psi
Leakage	0% for A to AB
Cv rating	A-port: see product chart for values

Valve Nominal Size			Type	Suitable Actuators		
Cv	Inches	DN [mm]	2-way Flange	Non-Spring	Spring	Electronic Fail-Safe
70	2½"	65	B6250S-070	AR Series	AFR Series	
110	2½"	65	B6250S-110			
110	3"	80	B6300S-110			
186	4"	100	B6400S-186	GR		GKR Series
290	5"	125	B6500S-290			
400	6"	150	B6600S-400			

Flow Pattern

2-way B6250 to B6600 Characterized Control Valves™

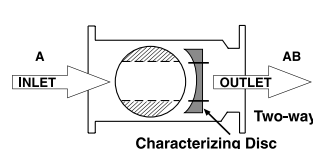

Upstream A
Downstream AB

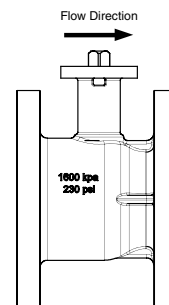

Dimensions

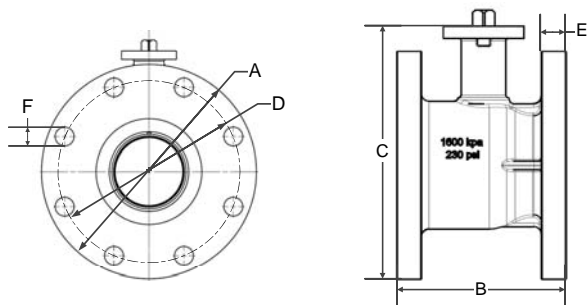

Valve Body	Nominal Pipe Size	Top Flange Design	Flange Diameter	Face-to-Face Length	Height
			A	B	C
B6250S	2½" [65]	F05	7.50" [190.5]	5.50" [139.7]	8.10" [205.4]
B6300S	3" [80]		8.00" [203.2]	6.60" [167.6]	8.40" [213.1]
B6400S	4" [100]		9.00" [228.6]	8.30" [210.8]	9.30" [235.9]
B6500S	5" [125]		10.00" [254.0]	10.30" [261.6]	10.50" [266.4]
B6600S	6" [150]		11.00" [279.4]	12.50" [317.5]	11.70" [296.9]

Bolt Circle Diameter	Flange Thickness Minimum	Bolt Hole Diameter	Number of Bolt Holes
D	E	F	
5.50" [139.7]	0.75" [19.05]	0.75" [19.05]	4
6.00" [152.4]	0.75" [19.05]	0.75" [19.05]	4
7.50" [190.5]	0.94" [23.88]	0.75" [19.05]	8
8.50" [215.9]	0.94" [23.88]	0.88" [22.35]	8
9.50" [241.3]	1.00" [25.40]	0.88" [22.35]	8

NOTES:

- 1) Flange bolt pattern matches ANSI class 125 flanges (not ANSI/ASME rated)
- 2) Maximum allowable working pressure: 100 PSIG
- 3) It is not recommended to connect raised-face flanges to flat-faced flanges



Models

GKRB24-3-5-14

Technical Data	
Control	on/off, floating point
Power supply	24 VAC ± 20% 50/60 Hz 24 VDC ± 10%
Power consumption	running 12 W holding 3 W
Transformer sizing	18 VA (Class 2 power source)
Electrical connection	3 ft, 18 GA plenum rated cable ½" conduit connector
Overload protection	electronic throughout 0° to 95° rotation
Input impedance	100 kΩ (0.1mA), 500 Ω, 1500 Ω (floating point, on/off)
Angle of rotation	max. 95°, adjustable with mechanical stop
Direction of rotation	reversible with switch
Position indication	visual indicator
Running time	running 150 seconds fail-safe 35 seconds
Manual override	external push button
Ambient temperature	-22°F to 122°F [-30°C to 50°C]
Housing	NEMA 2/IP54, Enclosure Type 2
Agency listings †	cULus according to UL 60730-1A/-2-14, CAN/CSA E60730-1:02, CE according to 2004/108/EEC and 2006/95/EC
Noise level	<45 dB(A)
Quality standard	ISO 9001

† Rated Impulse Voltage 800V, Type of action 1.AA (1.AA.B for -S version), Control Pollution Degree 3.

Dimensions

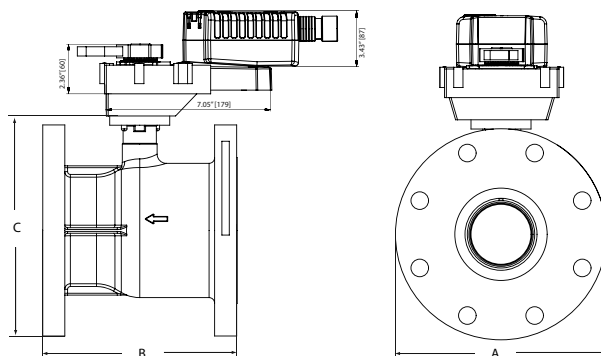

Valve Body	Nominal Pipe Size	Top Flange Design	Flange Diameter	Face-to-Face Length	Height
			A	B	C
B6500	5" [125]	F05	10.00" [254]	10.30" [261.6]	10.50" [266.4]
B6600	6" [150]		11.00" [279.4]	12.50" [317.5]	11.70" [296.9]

Electrical Installation

Wiring diagram

Note

- Connect via safety isolation transformer.
- Parallel connection of other actuators possible. Note performance data for supply.

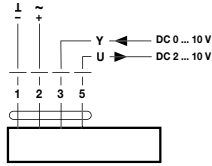

Cable lengths

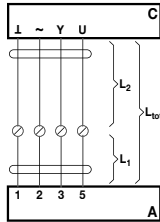

Note

When several actuators are connected in parallel, the maximum cable length must be divided by the number of actuators.

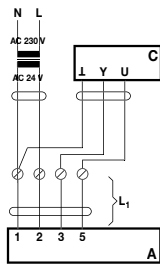

Note

There are no special restrictions on installation if the supply and data cable are routed separately.

Cable colors:
 1 = black
 2 = red
 3 = white
 5 = orange

A = Actuator
 C = Control unit
 L₁ = Belimo connecting cable, 1 m (4 x 0.75 mm²)
 L₂ = Customer cable
 L_{tot} = Maximum cable length

Cross section L ₂	Max. cable length L _{tot} = L ₁ + L ₂		Example for DC
	1 / ~ AC	DC	
0.75 mm ²	≤30 m	≤5 m	1 m (L ₁) + 4 m (L ₂)
1.00 mm ²	≤40 m	≤8 m	1 m (L ₁) + 7 m (L ₂)
1.50 mm ²	≤70 m	≤12 m	1 m (L ₁) + 11 m (L ₂)
2.50 mm ²	≤100 m	≤20 m	1 m (L ₁) + 19 m (L ₂)

A = Actuator
 C = Control unit
 L₁ = Belimo connecting cable, 1 m (4 x 0.75 mm²)

Wiring Diagrams

INSTALLATION NOTES

- 1 Provide overload protection and disconnect as required.
- 2 **CAUTION Equipment Damage!**
Actuators may be connected in parallel if not mechanically mounted to the same shaft. Power consumption and input impedance must be observed.
- 3 Actuators may also be powered by 24 VDC.
- 4 Position feedback cannot be used with Triac sink controller. The actuator internal common reference is not compatible.
- 5 Control signal may be pulsed from either the Hot (source) or the Common (sink) 24 VAC line.
- 8 Contact closures A & B also can be triacs. A & B should both be closed for triac source and open for triac sink.
- 9 For triac sink the common connection from the actuator must be connected to the hot connection of the controller.

APPLICATION NOTES

- Meets UL requirements without the need of an electrical ground connection.
- WARNING Live Electrical Components!**
During installation, testing, servicing and troubleshooting of this product, it may be necessary to work with live electrical components. Have a qualified licensed electrician or other individual who has been properly trained in handling live electrical components perform these tasks. Failure to follow all electrical safety precautions when exposed to live electrical components could result in death or serious injury.

