



- Fast quarter turn open or closed operation
- Stainless steel ball and stem
- Positive shut-off
- Two-piece body construction

Application

- Water-side control of air handling apparatus in ventilation and air-conditioning system
- Water/Steam control in heating systems
- 300:1 rangeability

The dimensions and drilling of end flanges conform to the American cast iron flange standard, Class 150 (ANSI B16.1).

Technical Data

Media	chilled or hot water, glycol, 250# steam
Flow characteristic	equal percentage
Action	90% rotation valve open CW, valve closed CCW
Sizes	3", 4", 6"
Type of end fittings	flanged

Materials:

Body	Carbon Steel
Ball	Stainless Steel with Hardened Chrome Plating
Seats	Teflon
Stem	Stainless Steel
Packing	Spring-loaded Teflon

Pressure rating	ANSI 150
Media temp. range	-22°F to 400°F (-30°C to 204°C)
Close-off pressure	150 psig @ 400°F
Maximum differential pressure (ΔP)	steam: 100psi water: 150psi

Cv	Valve Nominal Size		Type	Suitable Actuators		
	Inches	DN [mm]	2-way NPT	Spring	Electronic Fail-Safe	Non-Spring
207	3"	80	B6300VB-207	AF		GM AM Series
350	4"	100	B6400VB-350		GK	
507	6"	150	B6600VB-507			SY Series

GKX24-MFT-X1 Actuators

Multi-Function Technology



MFT



Models
GKX24-MFT-X1



Technical Data	
Power supply	24VAC ±20% 50/60Hz 24VDC ±10%
Power consumption	15W (1.5W)
Transformer sizing	20VA (class 2 power source)
Electrical connection	18 GA plenum rated Cable ½" conduit connector protected NEMA 2 (IP54) 3 ft [1m] 10 ft [3m] 16 ft [5m]
Overload protection	electronic throughout 0 to 95 rotation
Operation range Y	2 to 10 VDC, 4 to 20mA (default) variable (VDC,PWM, floating point, on-off)
Input impedance	100 kΩ (0.1 mA), 500 Ω 1500 Ω (PWM, floating point, on/off)
Feedback output U	2 to 10VDC, 0.5mA max VDC variable
Angle of rotation	max. 95°, adjustable with mechanical stop electronically variable
Torque	360 in-lb [40Nm]
Direction of rotation	reversible with switch
Fail-safe position	adjustable with knob or tool 0 to 100%
Position indication	reflective visual indicator (snap-on)
Manual override	external push button
Running time	normal operation 95 seconds (default), variable 90 to 150 seconds fail-safe 35 seconds
Humidity	5 to 95% RH non-condensing (EN 60730-1)
Ambient temperature	-22°F to +122°F [-30°C to +50°C]
Storage temperature	-40°F to +176°F [-40°C to +80°C]
Housing	NEMA2, IP54, UL enclosure type 2
Housing material	UL94-5VA
Agency list	cULus acc. to UL 60730-1A/-2-14 CAN/CSA E60730-1:02 CE acc. to 2004/108/EEC and 2006/95/EC
Noise level	< 45dB(A) at 90 seconds
Servicing	maintenance free
Quality standard	ISO 9001
Weight	3.85 lbs [1.75 kg]

Dimensions with 2-Way Valve

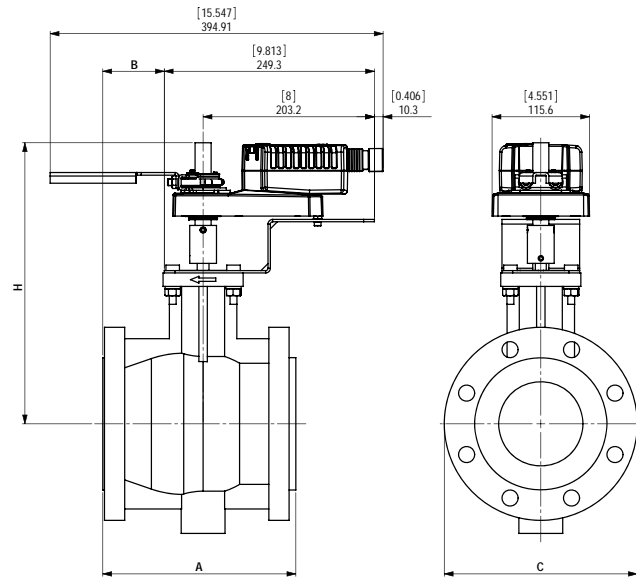

Valve Body	COP	Valve Nominal Size		Dimensions (Inches)			
		Inches	DN [mm]	A	B	C	H
B6400VB-350	150	4"	100	9.02	2.87	9.02	13.13

M40025 - 05/10 - Subject to change. © Belimo Aircontrols (USA), Inc.

Wiring Diagrams

INSTALLATION NOTES

- 1 Provide overload protection and disconnect as required.
- 2 **CAUTION Equipment Damage!**
Actuators may be connected in parallel if not mechanically mounted to the same shaft. Power consumption and input impedance must be observed.
- 4 Position feedback cannot be used with Triac sink controller. The actuator internal common reference is not compatible.
- 5 Control signal may be pulsed from either the Hot (source) or the Common (sink) 24 VAC line.
- 8 Contact closures A & B also can be triacs. A & B should both be closed for triac source and open for triac sink.

APPLICATION NOTES

- ◆ Meets UL requirements without the need of an electrical ground connection.

WARNING Live Electrical Components!
During installation, testing, servicing and troubleshooting of this product, it may be necessary to work with live electrical components. Have a qualified licensed electrician or other individual who has been properly trained in handling live electrical components perform these tasks. Failure to follow all electrical safety precautions when exposed to live electrical components could result in death or serious injury.

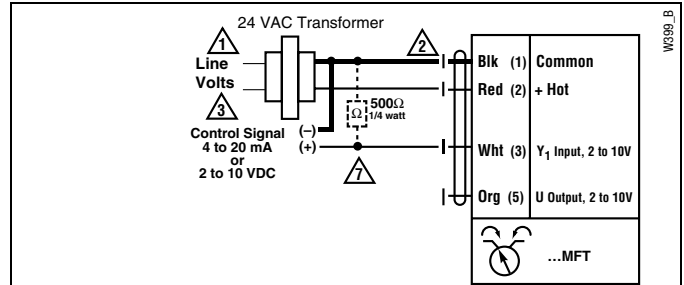

VDC/4-20 mA

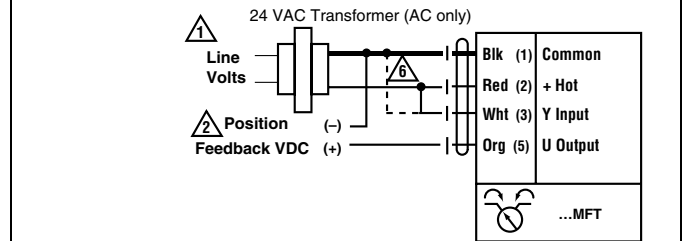

PWM

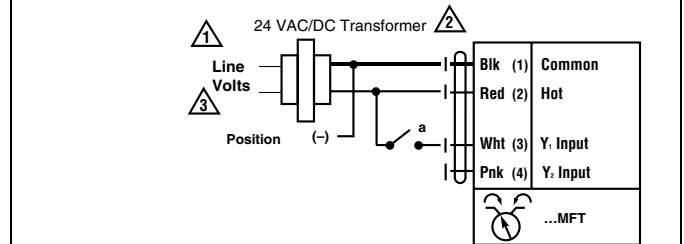

On/Off

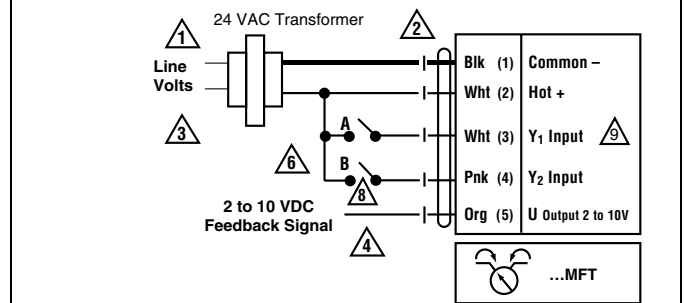

Floating Point

Valve Installation Procedure

3", 4" & 6" Valves - Flanged Installation

1. Valve must be in the closed position for installation.
2. **Figure 1 illustrates a flanged valve installation.**
3. Use hex bolts & nuts to secure valve to flange.
4. Ensure proper gaskets are used between the valve flange and pipe flange.
5. Tighten bolts & nuts in alternating opposite sides until completely tightened. Please see torque requirements below. Torque wrench is required.

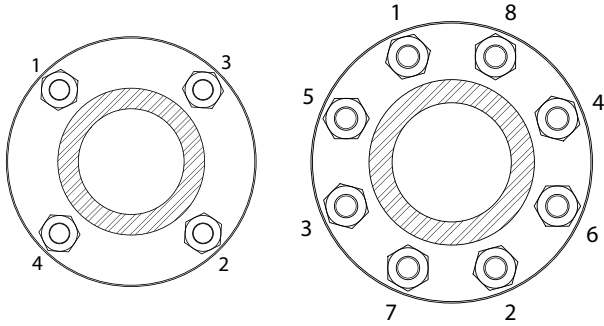

3" Bolt Tightening Sequence

4" & 6" Bolt Tightening Sequence



WARNING: Exceeding the Maximum Torque Can Damage the Valve and Void the Warranty!

- 3" ANSI 150 Flange - 65 ft/lbs
- 4" ANSI 150 Flange - 70 ft/lbs
- 6" ANSI 150 Flange - 100 ft/lbs

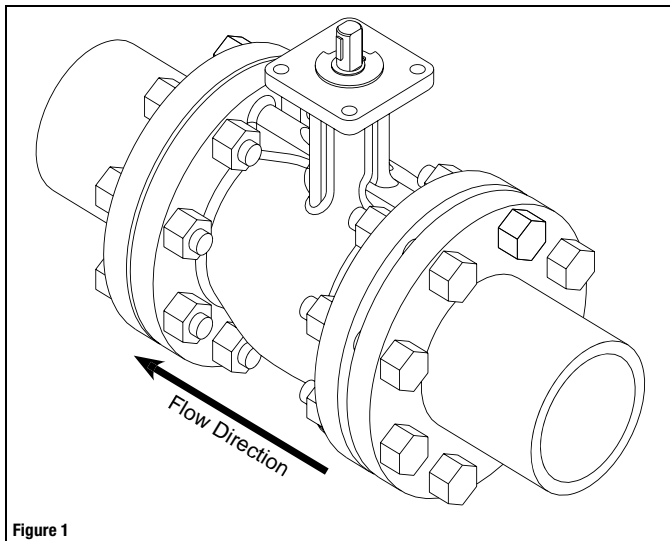

Figure 1

Seat Replacement Procedure

3", 4" & 6" Valves

1. Remove valve from pipe
2. Remove 2 cap retaining washers (1)
3. Using 2 wrenches/flat-head screwdrivers, pry cap assembly (2) out of valve
4. Rotate valve to fully open position
5. Using hands, pull seat (3) out of the valve
6. Replace seat and reverse procedure to reassemble
7. Reinstall valve per installation instructions

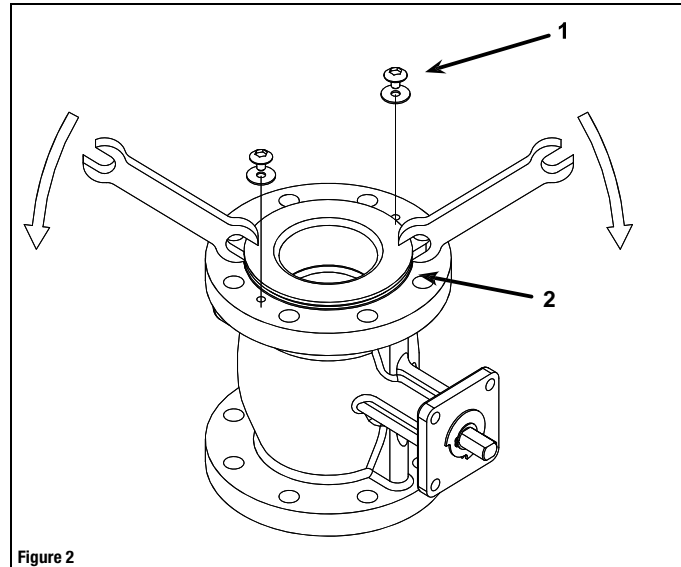

Figure 2

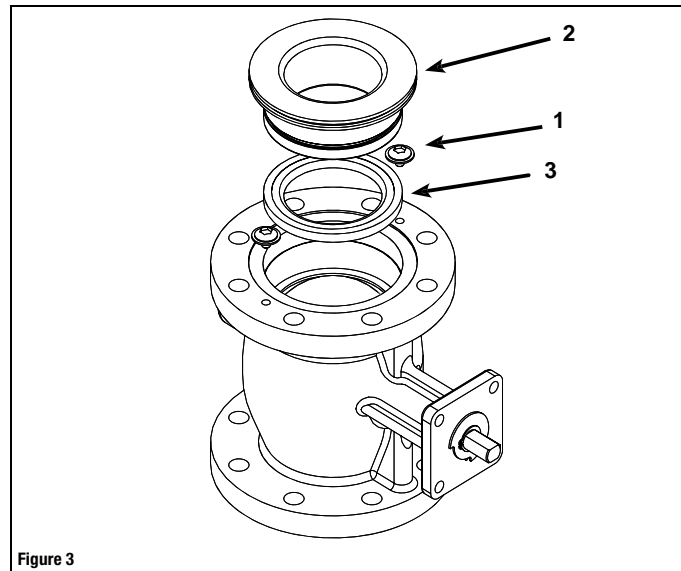

Figure 3