



- Bubble tight shut-off to ANSI Class 300 Standards
- Long stem design allows for 2" insulation minimum
- Valve Face-to-face dimensions comply with API 609 & MSS-SP-68
- Designed to be installed between ASME/ANSI B16.5 Flanges
- Completely assembled and tested, ready for installation

Application

These valves are designed to meet the needs of HVAC and Commercial applications requiring positive shut-off for liquids at higher pressures and temperatures. Typical applications include chiller isolation, cooling tower isolation, change-over systems, large air handler coil control, bypass and process control applications. The large C_v values provide for an economical control valve solution for larger flow applications.

Technical Data	
Media service	chilled, hot water, 60% glycol, steam to 50 psi
Valve service	double dead end service
Flow characteristic	modified equal percentage, unidirectional
Recommended install	SUS (Seat Up Stream)
Action	quarter turn, mechanically limited
Sizes	2" to 24"
Type of end fitting	for use with ASME/ANSI B16.5 flanges
Materials	
Body	carbon steel full lug
Disc	316 stainless steel
Seat	RPTFE
Shaft	17-4 PH stainless
Gland seal	PTFE
Bushings	glass backed PTFE
Media temperature range	ANSI Class 300 limitations
Operation ambient temperature range	-22°F to 122°F [-30°C to 50°C]
Body pressure rating	ASME/ANSI Class 300 limitations
Close-off pressure	ANSI Class 300 to 725 psi @ 100°F
Rangeability	10:1 (for 30 deg to 70 deg range)
Maximum velocity	32 FPS

C _v 90°	C _v 60°	Valve Nominal Size	Type	Suitable Actuators	
				Spring	Non-Spring
100	52	2"	F650-300SHP	AF Series	GM Series
143	75	2½"	F665-300SHP		
223	117	3"	F680-300SHP		
435	228	4"	F6100-300SHP	SY Series	
688	361	5"	F6125-300SHP		
1041	546	6"	F6150-300SHP		
1911	1001	8"	F6200-300SHP		
3194	1673	10"	F6250-300SHP		
4428	2319	12"	F6300-300SHP		
5702	2986	14"	F6350-300SHP		
8243	3988	16"	F6400-300SHP		
9712	5088	18"	F6450-300SHP		
10658	5775	20"	F6500-300SHP		
16205	8855	24"	F6600-300SHP		

M40048 - 06/10 - Subject to change. © Belimo Aircontrols (USA), Inc.

Valve	Size	C _v	MOD									ON/OFF
			10°	20°	30°	40°	50°	60°	70°	80°	90°	
F650-300SHP	2"	100	1.40	6.00	13	24	36	52	71	95	100	
F665-300SHP	2.5"	143	2.10	8.00	19	34	52	75	102	136	143	
F680-300SHP	3"	223	3.20	13	30	53	81	117	159	212	223	
F6100-300SHP	4"	435	6.20	25	58	104	157	228	310	414	435	
F6125-300SHP	5"	688	10	40	92	165	248	361	491	655	688	
F6150-300SHP	6"	1041	15	60	139	250	377	546	744	992	1041	
F6200-300SHP	8"	1911	27	109	255	459	692	1001	1365	1820	1911	
F6250-300SHP	10"	3194	46	183	426	767	1156	1673	2282	3042	3194	
F6300-300SHP	12"	4428	63	253	590	1063	1602	2319	3163	4217	4428	
F6350-300SHP	14"	5702	81	326	760	1368	2063	2986	4072	5430	5702	
F6400-300SHP	16"	8243	109	435	1015	1827	2755	3988	5438	7850	8243	
F6450-300SHP	18"	9712	139	555	1295	2331	3515	5088	6938	9250	9712	
F6500-300SHP	20"	10658	158	630	1470	2646	3990	5775	7875	10150	10658	
F6600-300SHP	24"	16205	242	966	2254	4057	6118	8855	12075	16100	16205	

F6 ANSI Class 300 Reinforced Teflon Seat, 316 Stainless Disc



Maximum Dimensions (Inches)

Valve	Size	C _v 90°	A	B	C	D(Max)	BHC	No. of Holes	Lug Bolt	Actuator	Close-Off (PSI)	
F650-300SHP	2"	100	1.75	9.00	9.00	19.50	5.00	8	5/8-11 UNC	2*AF	150	Fail Safe
F665-300SHP	2.5"	143	1.88	9.00	9.00	20.00	5.88	8	3/4-10 UNC		150	
F680-300SHP	3"	223	1.92	9.00	9.00	20.50	6.63	8	3/4-10 UNC		150	
F6100-300SHP	4"	435	2.13	9.00	9.00	21.00	7.88	8	3/4-10 UNC		150	
F650-300SHP	2"	100	1.75	9.00	9.00	19.50	5.00	8	5/8-11 UNC	GMB(X)	285	
F665-300SHP	2.5"	143	1.88	9.00	9.00	20.00	5.88	8	3/4-10 UNC		285	
F680-300SHP	3"	223	1.92	9.00	9.00	20.50	6.63	8	3/4-10 UNC		285	
F6100-300SHP	4"	435	2.13	9.00	9.00	21.00	7.88	8	3/4-10 UNC		150	
F650-300SHP	2"	100	1.75	9.00	9.00	19.50	5.00	8	5/8-11 UNC	2*GMB(X)	600	
F665-300SHP	2.5"	143	1.88	9.00	9.00	20.00	5.88	8	3/4-10 UNC		600	
F680-300SHP	3"	223	1.92	9.00	9.00	20.50	6.63	8	3/4-10 UNC		600	
F6100-300SHP	4"	435	2.13	9.00	9.00	21.00	7.88	8	3/4-10 UNC		400	
F650-300SHP	2"	100	1.75	8.00	8.00	22.25	4.75	8	5/8-11 UNC	SY2...	600	
F665-300SHP	2.5"	143	1.88	8.00	8.00	22.75	5.50	8	3/4-10 UNC		600	
F680-300SHP	3"	223	1.92	8.00	8.00	23.00	6.00	8	3/4-10 UNC		600	
F6100-300SHP	4"	435	2.13	8.00	8.00	23.75	7.50	8	3/4-10 UNC		600	
F6125-300SHP	5"	688	2.25	8.00	8.00	24.25	8.50	8	3/4-10 UNC	SY2...	285	Non-Fail Safe
										SY3...	600	
F6150-300SHP	6"	1041	2.29	8.00	8.00	24.75	9.50	12	3/4-10 UNC	SY2...	285	
										SY3...	600	
F6200-300SHP	8"	1911	2.88	12.00	12.00	32.00	11.75	12	7/8-9 UNC	SY3...	150	
										SY4...	600	
										SY4...	285	
F6250-300SHP	10"	3194	3.25	12.00	12.00	33.00	14.25	16	1-8 UNC	SY5...	400	
										SY7...	600	
										SY4...	150	
F6300-300SHP	12"	4428	3.62	12.00	12.00	35.00	17.00	16	1 1/8-8 UNC	SY5...	285	
										SY7...	600	
										SY5...	150	
F6350-300SHP	14"	5702	4.62	14.00	14.00	36.00	18.75	20	1 1/8-8 UNC	SY7...	400	
										SY8...	600	
										SY7...	150	
F6400-300SHP	16"	8243	5.25	14.00	14.00	37.50	21.25	20	1 1/4-8 UNC	SY8...	285	
										SY9...	400	
										SY10...	600	
										SY7...	150	
F6450-300SHP	18"	9712	5.88	14.00	14.00	42.25	22.75	24	1 1/4-8 UNC	SY8...	285	
										SY9...	400	
										SY11...	600	
										SY8...	150	
F6500-300SHP	20"	10658	6.31	14.00	14.00	49.50	25.00	24	1 1/4-8 UNC	SY10...	285	
										SY11...	400	
F6600-300SHP	24"	16205	7.19	14.00	14.00	56.25	29.50	24	1 1/2-8 UNC	SY10...	150	

Dimensions

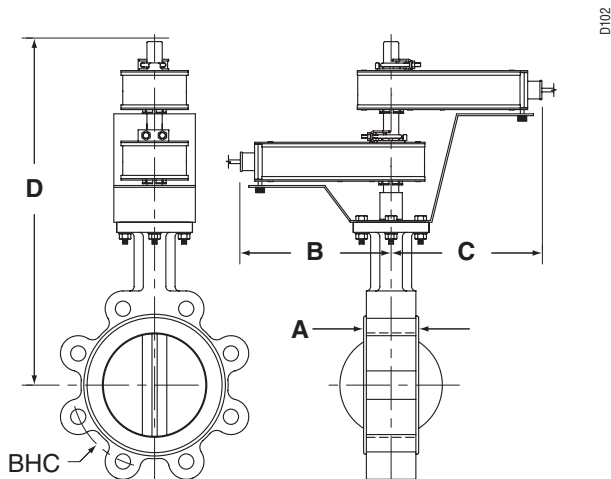

Dimension "A" does not include flange gaskets. (2 required per valve)

Application Notes

1. Valves are rated at 725 psi differential pressure in the closed position @ 100°F media temperature.
2. Valves are furnished with lugs tapped for use between ANSI Class 250/300 flanges conforming to ANSI B16.5 Standards.
3. 2-way assemblies are furnished assembled, calibrated and tested, ready for installation.
4. Dimension "D" allows for actuator(s) removal without the need to remove the valve from the pipe.
5. Weather shields are available, dimensional data furnished upon request.
6. Dual actuated valves have actuators mounted on a single common shaft.
7. Flange gaskets (2 required, not provided with valve) MUST be used between valve and ANSI flange.
8. Flange bolts are not included with the valve. These are furnished by others.

M40048 - 06/10 - Subject to change. © Belimo Aircontrols (USA), Inc.

GMB24-3-X1 Actuators, On/Off, Floating Point

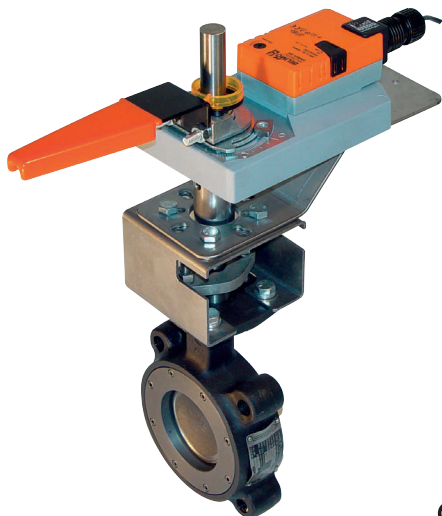

Models

GMB24-3-X1

Technical Data	
Power supply	24 VAC ± 20% 50/60 Hz 24 VDC ± 10%
Power consumption	running 4.0 W holding 2 W
Transformer sizing	6 VA (class 2 power source)
Electrical connection	3 ft, 18 GA appliance cable, 1/2" conduit connector
Overload protection	electronic throughout 0 to 95° rotation
Control signal	On/Off, Floating Point
Input impedance	600 Ω
Angle of rotation	mechanically limited to 95°
Direction of rotation	reversible with switch A/B
Position indication	0 to 1 and reversible indicator
Running time	150 sec.
Humidity	5 to 95% RH non-condensing
Ambient temperature	-22°F to 122°F [-30°C to 50°C]
Storage temperature	-40°F to 176°F [-40°C to 80°C]
Housing	NEMA 2/IP54
Housing material	UL94-5VA (flammability rating)
Agency listings	cULus according to UL60730-1A/-2-14, CAN/CSA E60730-1, CSA C22.2 No.24-93, CE according to 89/336/EEC
Noise level	max. 45 dB (A)
Servicing	maintenance free
Quality standard	ISO 9001

Dimensions with 2-Way Valve

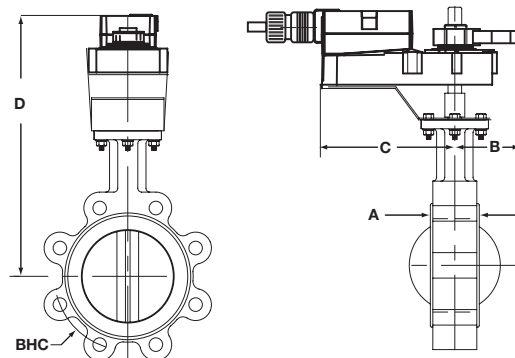

AM_GM_LineRevised

Valve	Size	Dimensions (Inches)					Non-Fail Safe (psi)	
		A	B	C	D(Max)	BHC	GM	2*GM
F680HD	3"	1.78	7.00	7.00	16.00	6.00	200	
F6100HD	4"	2.05	8.00	8.00	17.00	7.50	200	
F6100HDU	4"	2.05	8.00	8.00	17.00	7.50	50	
F6125HDU	5"	2.14	8.00	8.00	17.50	8.50	50	
F6150HDU	6"	2.19	8.00	8.00	22.50	9.50	50	
F650-150SHP	2"	1.75	9.00	9.00	19.50	4.75	285	
F665-150SHP	2½"	1.88	9.00	9.00	20.00	5.50	285	
F680-150SHP	3"	1.92	9.00	9.00	20.50	6.00	285	
F6100-150SHP	4"	2.13	9.00	9.00	21.00	7.50	150	285
F650-300SHP	2"	1.75	9.00	9.00	19.50	5.00	285	400
F665-300SHP	2½"	1.88	9.00	9.00	20.00	5.88	285	400
F680-300SHP	3"	1.92	9.00	9.00	20.50	6.63	285	400
F6100-300SHP	4"	2.13	9.00	9.00	21.00	7.88	150	285

IM40048 - 06/10 - Subject to change. © Belimo Aircontrols (USA), Inc.

Dimensions with 3-Way Valve

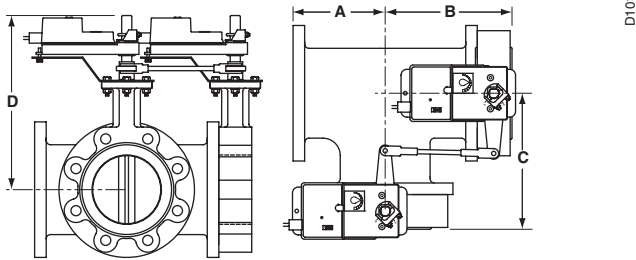

Dimensions (Inches) Non-Fail Safe (psi)

Valve	Size	A	B	C	D(Max)	BHC	GM	2*GM
F765HD	2½"	5.00	6.70	6.70	16.00	5.50	200	
F780HD	3"	5.50	7.20	7.20	16.25	6.00		200
F780HDU	3"	5.50	7.20	7.20	16.25	6.00	50	
F7100HD	4"	6.50	8.45	8.45	17.00	7.50		200
F7100HDU	4"	6.50	8.45	8.45	17.00	7.50		50
F7125HDU	5"	7.50	9.60	9.60	17.50	8.50		50
F7150HDU	6"	8.00	10.08	10.08	18.00	9.50		50
F750-150SHP	2"	4.50	6.25	6.25	16.50	4.75	150	285
F765-150SHP	2½"	5.00	6.88	6.88	17.00	5.50	150	285
F780-150SHP	3"	5.50	7.42	7.42	17.50	6.00	150	285
F7100-150SHP	4"	6.50	8.63	8.63	18.00	7.50	150	
F750-300SHP	2"	5.00	6.75	6.75	15.50	5.00		285
F765-300SHP	2½"	5.50	7.38	7.38	16.00	5.88		285
F780-300SHP	3"	6.00	7.92	7.92	16.25	6.63		285
F7100-300SHP	4"	7.00	9.13	9.13	18.00	7.88		150

Wiring Diagrams

✂️ INSTALLATION NOTES

2 **CAUTION Equipment damage!**
Actuators may be connected in parallel.
Power consumption and input impedance must be observed.

3 Actuators may also be powered by 24 VDC.

5 Actuators with plenum rated cable do not have numbers on wires; use color codes instead. Actuators with appliance cables are numbered.

📄 APPLICATION NOTES

◆ Meets cULus or UL and CSA requirements without the need of an electrical ground connection.

⚠️ WARNING Live Electrical Components!
During installation, testing, servicing and troubleshooting of this product, it may be necessary to work with live electrical components. Have a qualified licensed electrician or other individual who has been properly trained in handling live electrical components perform these tasks. Failure to follow all electrical safety precautions when exposed to live electrical components could result in death or serious injury.

