

- Bubble tight shut-off to ANSI Class 150 Standards
- Long stem design allows for 2" insulation minimum
- Valve Face-to-face dimensions comply with API 609 & MSS-SP-68
- Designed to be installed between ASME/ANSI B16.5 Flanges
- Completely assembled and tested, ready for installation
- Tees comply with ASME/ANSI B16.1 Class 125 Flanges

### Application

These valves are designed to meet the needs of HVAC and Commercial applications requiring positive shut-off for liquids at higher pressures and temperatures. Typical applications include chiller isolation, cooling tower isolation, change-over systems, large air handler coil control, bypass and process control applications. The large C<sub>v</sub> values provide for an economical control valve solution for larger flow applications.

Technical Data	
Media service	chilled, hot water, 60% glycol, steam to 50 psi
Valve service	double dead end service
Flow characteristic	modified linear, unidirectional
Recommended install	SUS (Seat Up Stream)
Action	quarter turn, mechanically limited
Sizes	2" to 24"
Type of end fitting	for use with ASME/ANSI B16.5 flanges
Materials	
Body	carbon steel full lug
Disc	316 stainless steel
Seat	RPTFE
Shaft	17-4 PH stainless
Gland seal	PTFE
Bushings	glass backed PTFE
Media temperature range	ANSI Class 150 limitations
Operation ambient temperature range	-22°F to 122°F [-30°C to 50°C]
Body pressure rating	ASME/ANSI Class 150 limitations
Close-off pressure	ANSI Class 150 to 285 psi @ 100°F
Rangeability	10:1 (for 30 deg to 70 deg range)
Maximum velocity	32 FPS

C <sub>v</sub> 90°	C <sub>v</sub> 60°	Valve Nominal Size	Type	Suitable Actuators	
				Spring	Non-Spring
102	56	2"	F750-150SHP	AF Series	GM Series
146	80	2½"	F765-150SHP		
228	125	3"	F780-150SHP		
451	248	4"	F7100-150SHP		
714	392	5"	F7125-150SHP		
1103	607	6"	F7150-150SHP		
2064	1135	8"	F7200-150SHP		
3517	1934	10"	F7250-150SHP		
4837	2660	12"	F7300-150SHP		
6857	3592	14"	F7350-150SHP		
9287	4865	16"	F7400-150SHP	SY Series	
11500	3270	18"	F7450-150SHP		
14420	7590	20"	F7500-150SHP		
22050	11550	24"	F7600-150SHP		

Valve	Size	C <sub>v</sub>	MOD									ON/OFF
			10°	20°	30°	40°	50°	60°	70°	80°	90°	
F750-150SHP	2"	102	1.50	6.10	14	26	39	56	77	99	102	
F765-150SHP	2.5"	146	2.20	8.80	20	37	55	80	110	142	146	
F780-150SHP	3"	228	3.40	14	32	57	87	125	171	221	228	
F7100-150SHP	4"	451	6.80	27	63	114	171	248	338	437	451	
F7125-150SHP	5"	714	11	43	100	180	271	393	536	693	714	
F7150-150SHP	6"	1103	17	66	154	278	419	607	827	1070	1103	
F7200-150SHP	8"	2064	31	124	289	520	784	1135	1548	2002	2064	
F7250-150SHP	10"	3517	53	211	492	886	1336	1934	2638	3411	3517	
F7300-150SHP	12"	4837	73	290	677	1219	1838	2660	3628	4692	4837	
F7350-150SHP	14"	6857	103	411	960	1728	2606	3771	5143	6651	6857	
F7400-150SHP	16"	9287	139	557	1300	2340	3529	5108	6965	9008	9287	
F7450-150SHP	18"	11400	171	684	1596	2873	4332	6270	8550	11058	11400	
F7500-150SHP	20"	14420	216	865	2019	3634	5480	7931	10815	13987	14420	
F7600-150SHP	24"	22050	331	1323	3087	5557	8379	12128	16538	21389	22050	

M440048 - 06/10 - Subject to change. © Belimo Aircontrols (USA), Inc.

# F7 ANSI Class 150 Reinforced Teflon Seat, 316 Stainless Disc



## Maximum Dimensions (Inches)

Valve	Size	C <sub>v</sub> 90°	A	B	C	D(Max)	BHC	No. of Holes	Lug Bolt	Actuator	Close-Off (PSI)
F750-150SHP	2"	102	4.50	6.38	6.38	16.50	4.75	4	5/8-11	GMB(X)	150
F765-150SHP	2.5"	146	5.00	6.88	6.88	17.00	5.50	4	5/8-11		150
F780-150SHP	3"	228	5.50	7.56	7.56	17.50	6.00	4	5/8-11		150
F7100-150SHP	4"	451	6.50	8.63	8.63	18.00	7.50	8	5/8-11	2*GMB(X)	150
F750-150SHP	2"	102	4.50	6.38	6.38	16.50	4.75	4	5/8-11		285
F765-150SHP	2.5"	146	5.00	6.88	6.88	17.00	5.50	4	5/8-11		285
F780-150SHP	3"	228	5.50	7.56	7.56	17.50	6.00	4	5/8-11	285	
F750-150SHP	2"	102	4.50	6.38	6.38	22.25	4.75	4	5/8-11 UNC	SY2...	285
F765-150SHP	2.5"	146	5.00	6.88	6.88	22.75	5.50	4	5/8-11 UNC		285
F780-150SHP	3"	228	5.50	7.56	7.56	23.00	6.00	4	5/8-11 UNC		285
F7100-150SHP	4"	451	6.50	8.63	8.63	23.75	7.50	8	5/8-11 UNC	SY3...	285
F7125-150SHP	5"	714	7.50	9.75	9.75	24.25	8.50	8	3/4-10 UNC		285
F7150-150SHP	6"	1103	8.00	10.25	10.25	24.75	9.50	8	3/4-10 UNC		285
F7200-150SHP	8"	2064	9.00	11.50	11.50	32.00	11.75	8	3/4-10 UNC	SY4...	150
F7250-150SHP	10"	3517	11.00	13.81	13.81	33.00	14.25	12	7/8-9 UNC		150
F7300-150SHP	12"	4837	12.00	15.81	15.81	35.00	17.00	12	7/8-9 UNC		285
F7350-150SHP	14"	6857	14.00	17.62	17.62	36.00	18.75	12	1-8 UNC	SY7...	285
F7400-150SHP	16"	9287	15.00	19.00	19.00	37.50	21.25	16	1-8 UNC		150
F7450-150SHP	18"	11400	16.50	21.00	21.00	42.25	22.75	16	1 1/8-8 UNC		285
F7500-150SHP	20"	14420	18.00	23.00	23.00	49.50	25.00	20	1 1/8-8 UNC	SY9...	150
F7600-150SHP	24"	22050	22.00	28.06	28.06	56.25	29.50	20	1 1/4-8 UNC		285
											150

Non-Fail Safe

## Dimensions

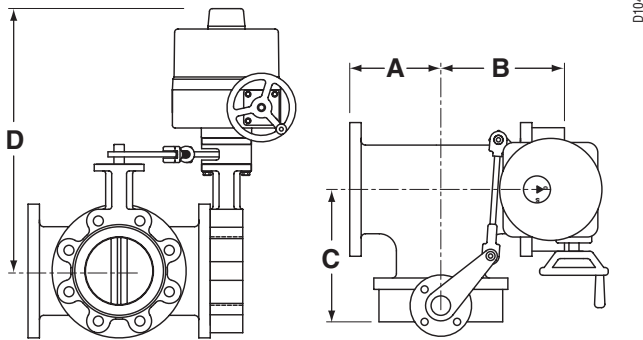

Dimensions "A, B and C" do not include flange gaskets. (3 required per valve)

## Application Notes

- Valves are rated at 285 psi differential pressure in the closed position @ 100°F media temperature.
- Valves are furnished with lugs tapped for use between ANSI Class 125/150 flanges conforming to ANSI B16.5 Standards.
- 3-way assemblies are furnished assembled with Tee, calibrated and tested, ready for installation. All 3-way assemblies require the customer to specify the 3-way configuration code prior to order entry to guarantee correct placement of valves and actuator(s) on the assembly.
- Dimension "D" allows for actuator(s) removal without the need to remove the valve from the pipe.
- Weather shields are available, dimensional data furnished upon request.
- Dual actuated valves have single actuators mounted on each valve shaft.
- Flange gaskets (3 required, not provided with valve) MUST be used between valve and ANSI flange.
- Flange bolts are not included with the valve. These are furnished by others.

**⚠ Note:** For tee configuration, please refer to page 5.

## Pressure/temperature chart for ANSI class butterfly valves.

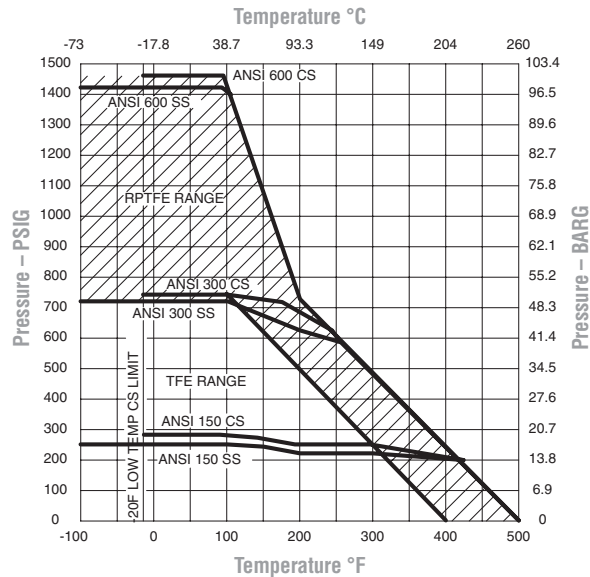

BF14\_A

IM40048 - 06/10 - Subject to change. © Belimo Aircontrols (USA), Inc.

**SHP series valves have a preferred flow direction.**

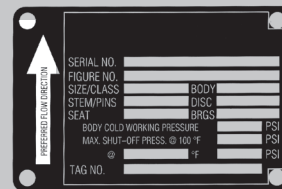

PreferredFlowRate



Technical Data	GKX24-MFT-X1
Power supply	24VAC ±20% 50/60Hz 24VDC ±10%
Power consumption	12W (3W)
Transformer sizing	21VA (class 2 power source)
Electrical connection	18 GA plenum rated cable ½" conduit connector protected NEMA 2 (IP54) 3 ft [1m] 10 ft [3m] 16 ft [5m]
Overload protection	electronic throughout 0 to 95 rotation
Operation range Y	2 to 10 VDC, 4 to 20mA (default) variable (VDC,PWM, floating point, on/off)
Input impedance	100kΩ (0.1 mA), 500Ω 1500Ω (PWM, floating point, on/off)
Feedback output U	2 to 10VDC, 0.5mA max, VDC variable
Angle of rotation	max. 95°, adjustable with mechanical stop electronically variable
Direction of rotation	reversible with  switch
Fail-safe position	adjustable with dial or tool 0 to 100% in 10% increments
Position indication	reflective visual indicator (snap-on)
Manual override	external push button
Running time	
normal operation	95 seconds (default), variable 90 to 150 seconds
fail-safe	35 seconds
Humidity	5 to 95% RH non-condensing (EN 60730-1)
Ambient temperature	-22°F to +122°F [-30°C to +50°C]
Storage temperature	-40°F to +176°F [-40°C to +80°C]
Housing	NEMA2, IP54, UL enclosure type 2
Housing material	UL94-5VA
Agency list	cULus acc. to UL 60730-1A/-2-14 CAN/CSA E60730-1:02 CE acc. to 2004/108/EEC and 2006/95/EC
Noise level	< 45dB(A)
Servicing	maintenance free
Quality standard	ISO 9001

## Dimensions with 2-Way Valve

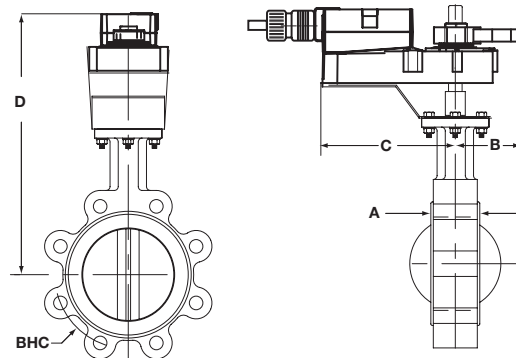

AM\_GM\_LineRevised

Valve	Size	Dimensions (Inches)					Non-Fail Safe (psi)	
		A	B	C	D(Max)	BHC	GK	
F680HD	3"	1.69	9.00	9.00	21.03	6.00	200	
F6100HDU	4"	1.92	9.00	9.00	21.53	7.50	50	
F6125HDU	5"	2.08	9.00	9.00	22.53	8.50	50	
F650-150SHP	2"	1.75	9.00	9.00	20.03	4.75	285	
F665-150SHP	2½"	1.88	9.00	9.00	20.53	5.50	285	
F680-150SHP	3"	1.92	9.00	9.00	21.03	6.00	285	
F6100-150SHP	4"	2.13	9.00	9.00	21.53	7.50	150	
F650-300SHP	2"	1.75	9.00	9.00	20.03	5.00	285	
F665-300SHP	2½"	1.88	9.00	9.00	20.53	5.88	285	
F680-300SHP	3"	1.92	9.00	9.00	21.03	6.63	285	
F6100-300SHP	4"	2.13	9.00	9.00	21.53	7.88	150	

## Dimensions with 3-Way Valve

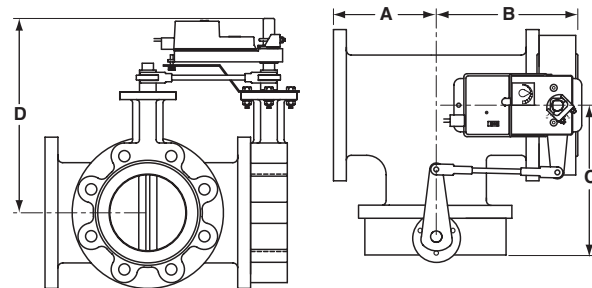

Single\_Butterfly

Valve	Size	Dimensions (Inches)				Non-Fail Safe (psi)	
		A	B	C	D(Max)	BHC	GK
F780HDU	3"	5.50	7.20	7.20	16.78	6.00	200
F750-150SHP	2"	4.50	6.25	6.25	17.03	4.75	150
F765-150SHP	2½"	5.00	6.88	6.88	17.53	5.50	150
F780-150SHP	3"	5.50	7.42	7.42	18.03	6.00	150

06/10 - Subject to change. © Belimo Aircontrols (USA), Inc.

## Wiring Diagrams

### INSTALLATION NOTES

- 1 Provide overload protection and disconnect as required.
- 3 Actuators may also be powered by 24 VDC.
- 4 Position feedback cannot be used with Triac sink controller. The actuator internal common reference is not compatible.
- 5 Control signal may be pulsed from either the Hot (source) or the Common (sink) 24 VAC line.
- 8 Contact closures A & B also can be triacs.
- 9 A & B should both be closed for triac source and open for triac sink.
- 9 For triac sink the common connection from the actuator must be connected to the hot connection of the controller.

### APPLICATION NOTES

- ◆ Meets UL requirements without the need of an electrical ground connection.
- ◆ The ZG-R01 500 Ω resistor may be used.

**WARNING Live Electrical Components!**  
 During installation, testing, servicing and troubleshooting of this product, it may be necessary to work with live electrical components. Have a qualified licensed electrician or other individual who has been properly trained in handling live electrical components perform these tasks. Failure to follow all electrical safety precautions when exposed to live electrical components could result in death or serious injury.

**NOTE: Wiring diagrams shown are for single actuator mounted solutions**

