



- 50 psi bubble tight shut-off
- Long stem design allows for 2" insulation
- Valve face-to-face dimensions comply with API 609 & MSS-SP-67
- Completely assembled and tested, ready for installation
- Tees comply with ASME/ANSI B16.1 Class 125 flanges

Application

These valves are designed to meet the needs of HVAC and commercial applications requiring bubble tight shut off for liquids. Typical applications include chiller isolation, cooling tower isolation, change-over systems, large air handler coil control, bypass and process control applications. The large C_v values provide for an economical control valve solution for larger flow applications. Designed for use in Victaulic piping systems when mated to Victaulic 41 series flange nipples.

Jobsite Note

Valves should be stored in a weather protected area prior to construction. Complete installation recommendations can be found in Belimo's Installation and Maintenance Instructions for F6/F7...HD/HDU Butterfly Valves.

Technical Data	
Service	chilled, hot water, 60% glycol
Flow characteristic	modified linear
Action	90° rotation
Sizes	2" to 12"
Type of end fitting	for use with ANSI 125/150 flanges
Materials	
Body	ductile iron ASTM A536
Body finish	epoxy powder finish
Disc	304 stainless steel
Seat	EPDM standard
Shaft	416 stainless steel
O-ring	EPDM
Upper bushing	RPTFE
Middle bushings	RPTFE
Lower bushing	RPTFE
Media temperature range	-22°F to 250°F [-30°C to 120°C]
Operation ambient temperature range	-22°F to 122°F [-30°C to 50°C]
Body pressure rating	ASME/ANSI Class 125/150 (200 psi at -30°F to 275°F)
Close-off pressure	50 psi
Rangeability	10:1 (for 30° to 70° range)
Maximum velocity	12 FPS

C _v 90°	C _v 60°	Valve Nominal Size		Type	Suitable Actuators			
		IN	DN [mm]		3-way	Spring	Non-Spring	
115	44	2"	50	F750HDU	AF Series	AM	GM Series	SY Series
196	75	2½"	65	F765HDU				
302	116	3"	80	F780HDU				
600	230	4"	100	F7100HDU				
1022	392	5"	125	F7125HDU				
1579	605	6"	150	F7150HDU				
3136	1202	8"	200	F7200HDU				
5340	2047	10"	250	F7250HDU				
8250	3062	12"	300	F7300HDU				

Valve	Size	C _v	MOD									ON/OFF
			10°	20°	30°	40°	50°	60°	70°	80°	90°	
F750HDU	2"	115	.06	3	7	15	27	44	70	105	115	
F765HDU	2½"	196	.10	6	12	25	45	75	119	178	196	
F780HDU	3"	302	.20	9	18	39	70	116	183	275	302	
F7100HDU	4"	600	.30	17	36	78	139	230	364	546	600	
F7125HDU	5"	1022	.50	29	61	133	237	392	620	930	1022	
F7150HDU	6"	1579	.80	45	95	205	366	605	958	1437	1579	
F7200HDU	8"	3136	2	89	188	408	727	1202	1903	2854	3136	
F7250HDU	10"	5340	3	151	320	694	1237	2047	3240	4859	5340	
F7300HDU	12"	8250	4	234	495	1072	1911	3062	5005	7507	8250	

M40048 - 06/10 - Subject to change. © Belimo Aircontrols (USA), Inc.

F7...HDU Butterfly Valves 2"-12" Ductile Iron Lug Body Resilient Seat, 304 Stainless Disc



Maximum Dimensions (Inches)

Valve	Size	C _v 90°	A	B	C	D(Max)	BHC	No. of Holes	Lug Bolt	Actuator	Close-Off (PSI)	
F750HDU	2"	115	4.50	6.15	6.15	15.50	4.75	4	5/8-11UNC	AF	50	Fail Safe
F765HDU	2½"	196	5.00	6.76	6.76	16.00	5.50	4	5/8-11UNC	2*AF	50	
F780HDU	3"	302	5.50	7.28	7.28	16.25	6.00	4	5/8-11UNC		50	
F750HDU	2"	115	4.50	6.15	6.15	15.50	4.75	4	5/8-11UNC	SY1...	50	Non-Fail Safe
F765HDU	2½"	196	5.00	6.76	6.76	16.00	5.50	4	5/8-11UNC		50	
F780HDU	3"	302	5.50	7.28	7.28	21.00	6.00	4	5/8-11UNC		50	
F7100HDU	4"	600	6.50	8.55	8.55	21.75	7.50	8	5/8-11UNC	SY2...	50	
F7125HDU	5"	1022	7.50	9.64	9.64	22.25	8.50	8	3/4-10UNC		50	
F7150HDU	6"	1579	8.00	10.19	10.19	22.75	9.50	8	3/4-10UNC		50	
F7200HDU	8"	3136	9.00	11.37	11.37	24.25	11.75	8	3/4-10UNC	SY3...	50	
F7250HDU	10"	5340	11.00	13.58	13.58	30.00	14.25	12	7/8-9UNC	SY4...	50	
F7300HDU	12"	8250	12.00	15.01	15.01	32.00	17.00	12	7/8-9UNC		50	

AF maximum actuator ambient temperature is 122°F.

SY... maximum actuator ambient temperature is 150°F.

Model SY1... does not have hand wheel-override is via 8mm wrench on bottom side of actuator.

Application Notes

1. Valves are rated at 50 psi differential pressure in the closed position.
2. Valves are furnished with lugs tapped for use with ANSI Class 125/150 flanges. Installation flanges and hardware are not included.
3. 3-way assemblies are furnished assembled and tested, ready for installation.
All 3-way assemblies require the customer to specify the 3-way configuration prior to order entry to guarantee correct placement of valves and actuators on the assembly.
4. Dimension "D" allows for actuator removal without the need to remove the valve from the pipe.
5. Weather shields are available, dimensional data upon request.
6. Dual actuated valves have single actuators mounted on each valve shaft.
7. Bolts supplied are for shipping purposes only. Upon installation replace with an appropriate SAE grade 5 or better hardware.
8. Belimo SY Series actuators are NEMA 4X rated.

Dimensions

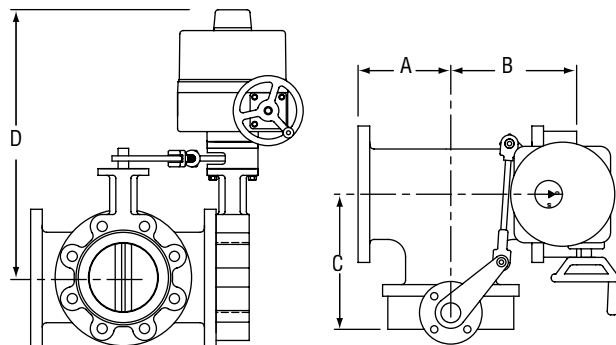

HS DWG#P15

M40048 - 06/10 - Subject to change. © Belimo Aircontrols (USA), Inc.



Models

AMX24-MFT-X1

Technical Data	
Power supply	24 VAC ± 20% 50/60 Hz 24 VDC ± 10%
Power consumption	running 4 W holding 1.25 W
Transformer sizing	6 VA (class 2 power source)
Electrical connection	□ 3 ft [1m] □ 10 ft [3m] □ 16 ft [5m] 18 GA plenum rated cable ½" conduit connector
Overload protection	electronic throughout 0° to 95° rotation
Operating range Y	2 to 10 VDC, 4 to 20 mA (default) Variable (VDC, PWM, Floating Point, On/Off)
Input impedance	100k Ω (0.1 mA), 500 Ω 1500 Ω (PWM, Floating Point, On/Off)
Feedback output U	2 to 10 VDC, 0.5 mA max VDC Variable
Angle of rotation	95° electronically variable
Direction of rotation	reversible with protected switch
Position indication	handle
Manual override	external push button
Running time	150 seconds (default) variable (90 to 350 secs)
Humidity	5 to 95% RH non condensing (EN 60730-1)
Ambient temperature	-22°F to +122°F [-30°C to +50°C]
Storage temperature	-40°F to +176°F [-40°C to +80°C]
Housing	NEMA 2/IP54
Housing material	UL94-5VA
Agency listings†	cULus according to UL60730-1A/-2-14, CAN/GSA E60730-1, CSA C22.2 No. 24-93, CE according to 89/336/EEC
Noise level	<45dB(A)
Quality standard	ISO 9001

† Rated impulse voltage 4kV, Control pollution degree 3, Type of action 1

Dimensions with 2-Way Valve

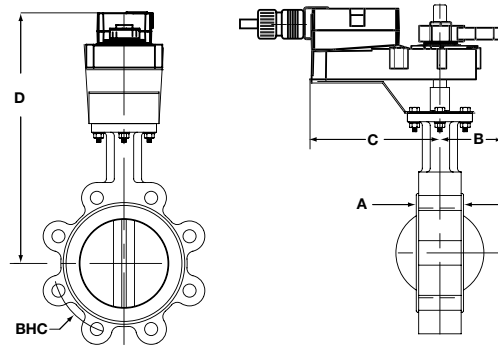

AM_GM_LineRevised

Dimensions (Inches)

Valve	Size	A	B	C	D(Max)	BHC	Non-Fail Safe (psi)
F650HD(U)	2"	1.65	7.00	7.00	15.00	4.75	
F665HD(U)	2½"	1.76	7.00	7.00	15.50	5.50	
F680HDU	3"	1.78	7.00	7.00	16.00	6.00	

Dimensions with 3-Way Valve

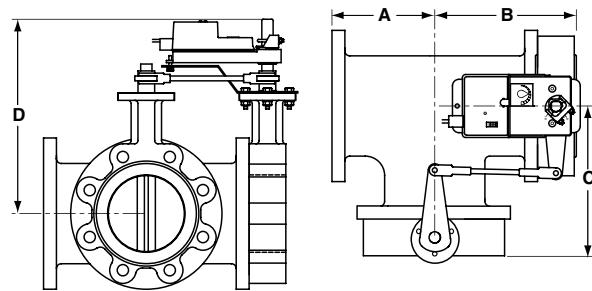

Single_Butterfly

Dimensions (Inches)

Valve	Size	Dimensions (Inches)					Non-Fail Safe (psi)	
		A	B	C	D(Max)	BHC	HD	HDU
F750HD	2"	4.50	6.15	6.15	15.50	4.75	200	
F765HDU	2½"	5.00	6.76	6.76	16.00	5.50	200	50

IM40048 - 06/10 - Subject to change. © Belimo Aircontrols (USA), Inc.

Wiring Diagrams

✂️ INSTALLATION NOTES

- ⚠️ 3 Actuators may also be powered by 24 VDC.
- ⚠️ 4 Position feedback cannot be used with Triac sink controller. The actuator internal common reference is not compatible.
- ⚠️ 6 Control signal may be pulsed from either the Hot (source) or the Common (sink) 24 VAC line.
- ⚠️ 8 Contact closures A & B also can be triacs.
- ⚠️ 8 A & B should both be closed for triac source and open for triac sink.
- ⚠️ 9 For triac sink the common connection from the actuator must be connected to the hot connection.

📄 APPLICATION NOTES

- ◆ The ZG-R01 500 Ω resistor converts the 4 to 20 mA control signal to 2 to 10 VDC, up to 2 actuators may be connected in parallel.

⚠️ WARNING Live Electrical Components!

During installation, testing, servicing and troubleshooting of this product, it may be necessary to work with live electrical components. Have a qualified licensed electrician or other individual who has been properly trained in handling live electrical components perform these tasks. Failure to follow all electrical safety precautions when exposed to live electrical components could result in death or serious injury.

