

G2...(S) 2-way Globe Valve, Bronze or Stainless Steel Trim



Technical Data		
	G2	G2...S
Service	chilled or hot water, 60% glycol, steam	
Flow characteristic	equal percentage	linear
Action	stem up - open A to AB	
Sizes	½" to 2"	
End fitting	NPT female ends	
Materials		
Body	bronze	bronze
Seat	bronze	stainless steel
Stem	stainless steel	stainless steel
Plug	brass	stainless steel
Packing	spring loaded TFE	spring loaded TFE
Disc	composition (EPDM)	Teflon
ANSI class	ANSI 250 (up to 400 psi below 150°F)	
Leakage	ANSI class IV	
Max steam inlet		
NV actuators	15 psi (103 kPa)	50 psi (345 kPa)
Rotary actuators	35 psi (241 kPa)	100 psi (689 kPa)
Media temperature		
Water	20°F to 250°F (-7°C to 120°C)	20°F to 300°F (-7°C to 149°C)
Maximum ΔP*		
Water	35 psi (241 kPa)	35 psi (241 kPa)
Steam (NV Actuator)	15 psi (103 kPa)	35 psi (241 kPa)
Steam (Rotary Actuator)	20 psi (138 kPa)	35 psi (241 kPa)
Rangeability	G2(S) 100:1	
Valve weights	G212(S), G213(S), G214(S), G215(S)	2 lbs
	G219(S), G220(S)	3 lbs
	G224(S), G225(S), G232(S)	5.5 lbs
	G240(S), G250(S)	13 lbs

*(50% or more open)

G2...(S) 2-way Flow Patterns

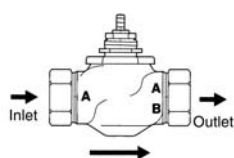

Flow Direction

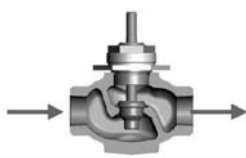

Stem Up - Open A to AB

Application

This valve is typically used in Air Handling Units on heating or cooling coils and Fan Coil Unit heating or cooling coils. Some other common applications include Unit Ventilators, VAV Box reheat coils and bypass loops. This valve is suitable for use in a hydronic system with variable flow.

Bronze and stainless steel trim valves can be used for steam applications, depending on actuator and close-off combinations.

C _v	Valve Nominal Size		Type	Suitable Actuators		
	Inches	DN [mm]	2-way NPT	Non-Spring	Spring	
0.4	½	15	G212(S)	LM Series	NV Series	LF Series
1.3	½	15	G213(S)			
2.2	½	15	G214(S)			
4.4	½	15	G215(S)			
5.5	¾	20	G219(S)			
7.5	¾	20	G220(S)	NM Series	NV Series	LF Series
10	1	25	G224(S)			
14	1	25	G225(S)			
20	1¼	32	G232(S)	AM Series	NV Series	AF(X)
28	1½	40	G240(S)			
40	2	50	G250(S)			NV Series

Dimensions

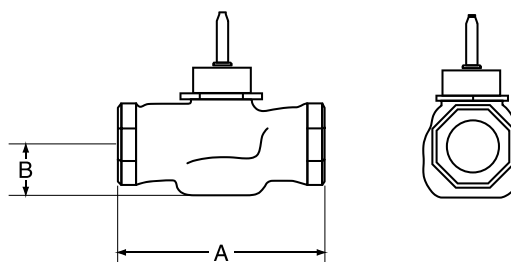

0081-2W

Valve Body	Valve Nominal Size		Dimensions (Inches [mm])	
	Inches	DN [mm]	A	B
G212(S)-G215(S)	½"	15	3.06" [78]	1.06" [27]
G219(S)-G220(S)	¾"	20	3.62" [92]	1.06" [27]
G224(S)-G225(S)	1"	25	4.62" [117]	1.12" [29]
G232(S)	1¼"	32	4.62" [117]	1.37" [35]
G240(S)	1½"	40	5.37" [137]	1.50" [38]
G250(S)	2"	50	6.12" [156]	1.56" [40]

Piping

The valves should be mounted in a weather-protected area in a location that is within the ambient limits of the actuator. Allow sufficient room for valve with actuator and for service. For the NV Series, allow 6" for cover removal and 12" for complete actuator removal. The G2(S) and G3(D) preferred mounting position of the valve is with the valve stem vertical above the valve body, for maximum life. However, the assemblies can be mounted with the valve stem vertical or horizontal in relation to the pipe. The actuators should never be mounted underneath the valve, as condensation can build up and result in a failure of the actuators. Do not reverse flow direction.

N40021 - 06/11 - Subject to change. © Belimo Aircontrols (USA), Inc.

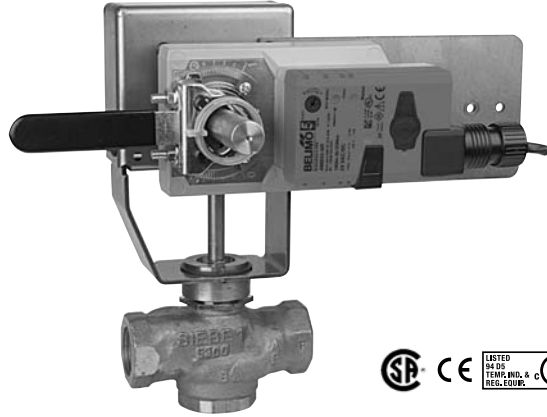

Models

AMB24-3-X1

AMB24-3-S-X1

w/built-in Aux. Switch

Technical Data		
Control		on/off, floating point
Power supply		24 VAC ± 20% 50/60 Hz 24 VDC ± 10%
Power consumption	running	2.5 W
	holding	0.2 W
Transformer sizing		5.5 VA (Class 2 power source)
Electrical connection		½" conduit connector
	AMB24-3-X1	3 ft, 18 GA plenum rated cable
	AMB24-3-S-X1	3 ft, 18 GA appliance cable
Overload protection		electronic throughout 0° to 95° rotation
Input impedance		600 Ω
Angle of rotation		max 95°, adjustable with mechanical stop
Torque		180 in-lb [20 Nm]
Direction of rotation		reversible with switch
Position indication		reflective visual indicator (snap-on)
Manual override		external push button
Running time		95 seconds, constant independent of load
Humidity		5 to 95% RH non-condensing (EN 60730-1)
Ambient temperature		-22° F to 122° F [-30° C to 50° C]
Storage temperature		-40° F to 176° F [-40° C to 80° C]
Housing		NEMA type 2/IP54
Housing material		UL94-5VA
Agency listings		cULus acc. to UL 60730-1/-2-14, CAN/GSA C22.2 No. 24 certified, CE acc. to 73/23/EEC
Noise level		<45 db(A)
Quality standard		ISO 9001
AMB24-3-S-X1		
Auxiliary switch		1 x SPDT, 6A (1.5A) @ 250 VAC, UL Listed, adjustable 0° to 95° (double insulated)

Dimensions with G2...(S) Series 2-Way Valve

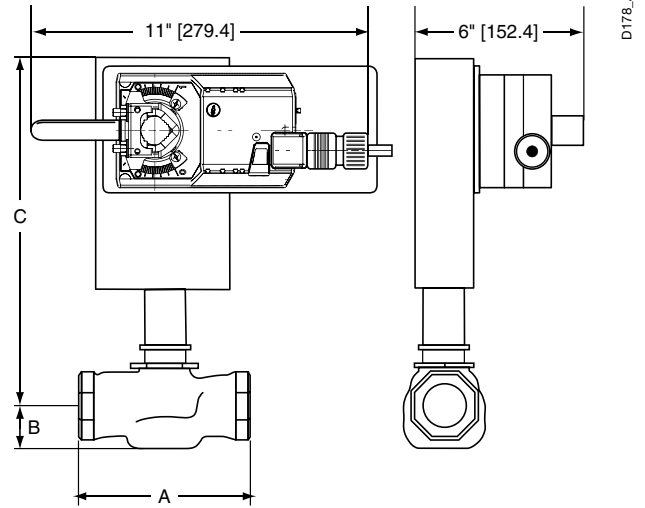

Valve Body	Valve Nominal Size		Dimensions (Inches [mm])		
	Inches	DN [mm]	A	B	C
G2(S)	1½"	40	5.37" [137]	1.50" [38]	8.50" [216]
G2(S)	2"	50	6.12" [156]	1.56" [40]	8.56" [217]

Dimensions with G3...(D) Series 3-Way Valve

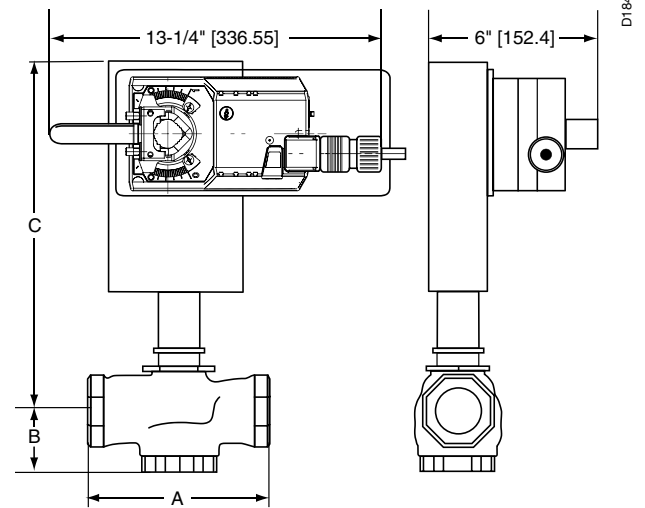

Valve Body	Valve Nominal Size		Dimensions (Inches [mm])		
	Inches	DN [mm]	A	B	C
G3(D)	1½"	40	5.37" [137]	1.62" [41]	8.62" [219]
G3(D)	2"	50	6.12" [156]	1.87" [48]	8.87" [225]

Wiring Diagrams

INSTALLATION NOTES

1 Provide overload protection and disconnect as required.

2 **CAUTION Equipment damage!**
Actuators may be connected in parallel.
Power consumption and input impedance must be observed.

3 Actuators may also be powered by 24 VDC.

5 Only connect common to neg. (-) leg of control circuits.

APPLICATION NOTES

Meets cULus or UL and CSA requirements without the need of an electrical ground connection.

WARNING Live Electrical Components!
During installation, testing, servicing and troubleshooting of this product, it may be necessary to work with live electrical components. Have a qualified licensed electrician or other individual who has been properly trained in handling live electrical components perform these tasks. Failure to follow all electrical safety precautions when exposed to live electrical components could result in death or serious injury.

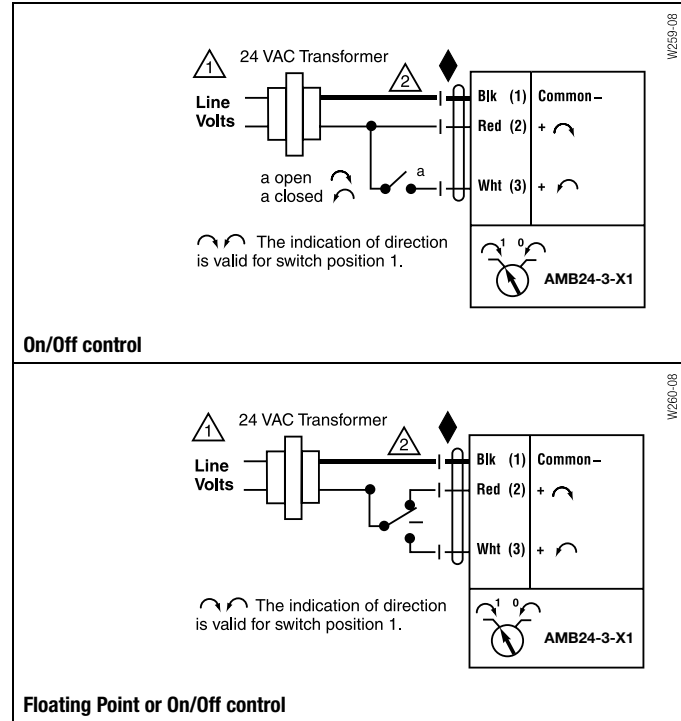

	Non-Spring Return						Spring Return					
	NVD	NV	NVG	LM	NM	AM	NVFD	NVF	LF	NF	AF	AFX
2-way												
G212(S)	250			250			250		250			
G213(S)	250			250			250		250			
G214(S)	250			250			250		250			
G215(S)	250			250			250		250			
G219(S)	250			242			250		185			
G220(S)	250			242			250		185			
G224(S)		250			250			207		250		
G225(S)		250			250			207		250		
G232(S)		162			158			130		158		
G240(S)		110	160			230		88			169	230
G250(S)		58	190			127		47			93	127
3-way Mixing												
G314	250			250			250		250			
G315	250			250			250		250			
G320	250			242			250		185			
G325		250			250			207		250		
G332		162			158			130		158		
G340		110				230		88			169	230
G350		58				127		47			93	127
3-way Diverting												
G315D	250			250			250		250			
G320D	250			250			250		250			
G325D	250				250		250			250		
G332D		250			250			250		250		
G340D		250				250		250			250	250
G350D		250				250		250			250	250