

G2...(S) 2-way Globe Valve, Bronze or Stainless Steel Trim



Technical Data		
	G2	G2...S
Service	chilled or hot water, 60% glycol, steam	
Flow characteristic	equal percentage	linear
Action	stem up - open A to AB	
Sizes	½" to 2"	
End fitting	NPT female ends	
Materials		
Body	bronze	bronze
Seat	bronze	stainless steel
Stem	stainless steel	stainless steel
Plug	brass	stainless steel
Packing	spring loaded TFE	spring loaded TFE
Disc	composition (EPDM)	Teflon
ANSI class	ANSI 250 (up to 400 psi below 150°F)	
Leakage	ANSI class IV	
Max steam inlet	35 psi (241 kPa)	100 psi (689 kPa)
Media temperature		
Water	20°F to 250°F (-7°C to 120°C)	20°F to 300°F (-7°C to 149°C)
Maximum ΔP*		
Water	35 psi (241 kPa)	35 psi (241 kPa)
Steam	20 psi (138 kPa)	35 psi (241 kPa)
Rangeability	G2(S) 100:1	
Valve weights		
	G212(S), G213(S), G214(S), G215(S)	2 lbs
	G219(S), G220(S)	3 lbs
	G224(S), G225(S), G232(S)	5.5 lbs
	G240(S), G250(S)	13 lbs

*(50% or more open)

G2...(S) 2-way Flow Patterns

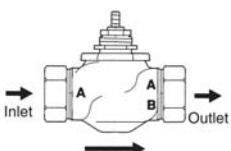

Flow Direction

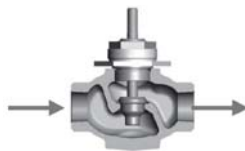

Stem Up - Open A to AB

Application

This valve is typically used in Air Handling Units on heating or cooling coils and Fan Coil Unit heating or cooling coils. Some other common applications include Unit Ventilators, VAV Box reheat coils and bypass loops. This valve is suitable for use in a hydronic system with variable flow.

Bronze and stainless steel trim valves can be used for steam applications, depending on actuator and close-off combinations.

Cv	Valve Nominal Size		Type	Suitable Actuators		
	Inches	DN [mm]	2-way NPT	Non-Spring	Spring	Electronic Fail-Safe
0.4	½	15	G212(S)	LV Series	LF Series	LVK Series
1.3	½	15	G213(S)			
2.2	½	15	G214(S)			
4.4	½	15	G215(S)			
5.5	¾	20	G219(S)			
7.5	¾	20	G220(S)	SV Series	NF Series	SVK Series
10	1	25	G224(S)			
14	1	25	G225(S)			
20	1¼	32	G232(S)			
28	1½	40	G240(S)	AF(X)		
40	2	50	G250(S)			

Dimensions

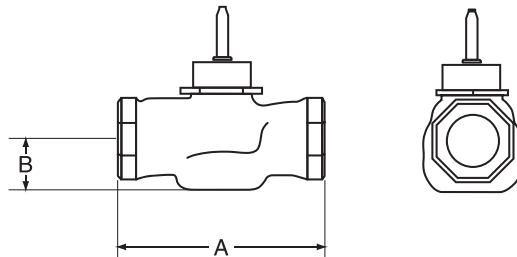

0031-2W

Valve Body	Valve Nominal Size		Dimensions (Inches [mm])	
	Inches	DN [mm]	A	B
G212(S)-G215(S)	½"	15	3.06" [78]	1.06" [27]
G219(S)-G220(S)	¾"	20	3.62" [92]	1.06" [27]
G224(S)-G225(S)	1"	25	4.62" [117]	1.12" [29]
G232(S)	1¼"	32	4.62" [117]	1.37" [35]
G240(S)	1½"	40	5.37" [137]	1.50" [38]
G250(S)	2"	50	6.12" [156]	1.56" [40]

Piping

The valves should be mounted in a weather-protected area in a location that is within the ambient limits of the actuator. Allow sufficient room for valve with actuator and for service. Please allow 12" for complete actuator/linkage removal. The G2(S) and G3(D) preferred mounting position of the valve is with the valve stem vertical above the valve body, for maximum life. However, the assemblies can be mounted with the valve stem vertical or horizontal in relation to the pipe. The actuators should never be mounted underneath the valve, as condensation can build up and result in a failure of the actuators. Do not reverse flow direction.

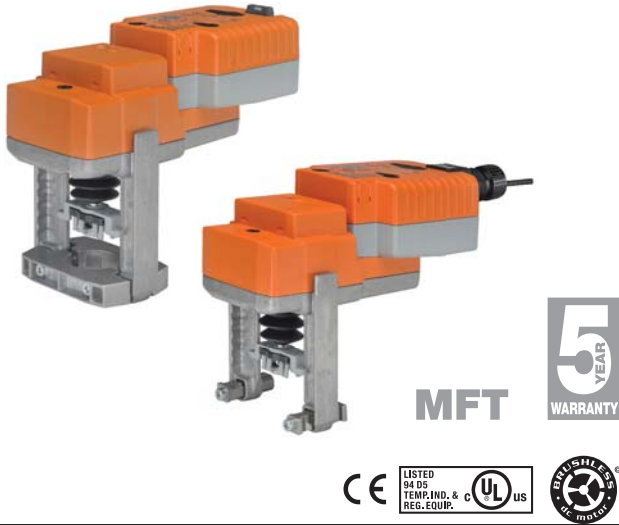

Technical Data	
Power supply	24 VAC ± 20% 50/60 Hz, 24 VDC ± 10%
Power consumption running	8.5 W
Power consumption holding	2.5 W
Transformer sizing	21 VA (class 2 power source)
Electrical connection	3 ft, 18 GA plenum rated cable with 1/2" conduit connector protected NEMA 2 (IP54)
Overload protection	electronic throughout full stroke
Electrical protection	actuators are double insulated
Control	Proportional/MFT
Operating Range Y	2 to 10 VDC, 4 to 20 mA (default), variable (VDC, PWM, floating point, on/off)
Input impedance	100 k Ω for 2 to 10 VDC (0.1 mA), 500 Ω for 4 to 20 mA, 1500 Ω for PWM, floating point and On/Off
Feedback Output U	2 to 10 VDC, 0.5 mA max, VDC variable
Stroke	0.75" [20 mm]
Linear Force	337 lbf [1500 N]
Direction of rotation	reversible with switch
Position indication	stroke indicator on bracket
Manual override	4 mm hex crank (shipped with actuator)
Running time motor	90 seconds (default), variable (90 to 150 seconds)
Running time fail-safe	35 seconds
Humidity	5 to 95% RH non condensing
Ambient temperature	-22°F to +122°F [-30°C to +50°C]
Storage temperature	-40°F to +176°F [-40°C to +80°C]
Housing	NEMA 2, IP54, UL enclosure type 2
Housing material	Aluminum die cast and plastic casing
Bridge Time	2 second delay before fail-safe activates
Initial Charge	5 to 20 seconds
Agency listings†	cULus acc. to UL 60730-1A/-2-14, CAN/CSA E60730-1:02, CE acc. to 2004/108/EC and 2006/95/EC
Noise level	<45dB(A)
Servicing	maintenance free
Quality standard	ISO 9001
Weight	3.6 lbs

† Use flexible metal conduit. Push the Listed conduit fitting device over the actuator's cable to butt against the enclosure. Screw in conduit connector. Jacket the actuators input wiring with Listed flexible conduit. Properly terminate the conduit in a suitable junction box. Rated impulse Voltage 800V. Type of action 1. Control Pollution Degree 3.

Application

Fail-safe for multiple control types of globe valves in HVAC steam and hydronic systems.

Actuator sizing will be dictated by the valve size selection. All valve selections should be done in accordance with the flow parameters and system specifications. The actuator is mounted directly to the globe valve bonnet by means of its universal clamp and collar.

The actuator operates in response to many controls types as desired by the customer and/or design control input from an electronic controller or positioner. A 2 to 10 VDC feedback signal is provided for position indication.

Operation

The actuator is not provided with and does not require any limit switches, but is electronically protected against overload. The SVK series provides 20 mm of downward travel and a visual indicator indicates position of the actuator. When reaching the valve end position, the actuator automatically stops. The gears can be manually disengaged with a button on the actuator cover.

The SVK... series actuators use a sensorless brushless DC motor. The ASIC inside monitors and controls the actuator's rotation and provides a digital rotation sensing (DRS) function to prevent damage to the actuator in a stall condition. Power consumption is reduced in holding mode.

Add-on auxiliary switches are easily fastened directly onto the actuator body for signaling and switching functions. -SR and -MFT models will have an illuminated green Adaption/Power button to reset and relearn the valve stroke as well as indicate the actuator is powered. This feature allows the actuator to rescale itself based on the actual travel. Along with the Adaption button on -MFT models will have a yellow Status light to confirm communication.

Fail-Safe Indication

LED status indicator lights sequence:

Yellow off / Green on: operation ok, no faults

Yellow off / Green blinking: fail-safe mechanism is active

Yellow on / Green off: fault is detected

Yellow off / Green off: not in operation / capacitors charging

Yellow on / Green on: adaption running

Yellow blinking / Green on: communication with programming tool

Dimensions (Inches [mm])

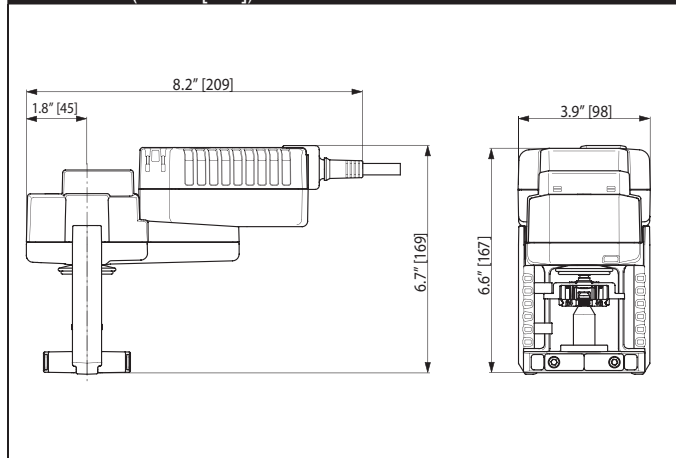

Typical Specification

Proportional control globe valve actuators shall be electronic and direct coupled to the globe valve bonnet via an integrated linkage, which requires no secondary linkage and be capable of mounting to valves ½" to 2" in size. Actuators must provide control in response to a control input from an electronic controller or positioner. Actuators shall have brushless DC motor technology and be protected from overload at all angles of rotation. Actuators shall have reversing switch and manual override on the cover. Run time shall be constant and independent of torque. Actuators shall be cULus listed, have a 5-year warranty, and be manufactured under ISO 9001 International Quality Control Standards. Actuators shall be as manufactured by Belimo.

Wiring Diagrams

INSTALLATION NOTES

- CAUTION Equipment Damage!**
- 2 Actuators may be connected in parallel if not mechanically mounted to the same shaft. Power consumption and input impedance must be observed.
- 3 Actuators may also be powered by 24 VDC.
- 7 a 500 Ω resistor converts the 4-20 mA control signal to 2-10 VDC
- 8 Control signal may be pulsed from either the Hot (Source) or Common (Sink) 24 VAC line.
- 9 For triac sink the common connection from the actuator must be connected to the hot connection of the controller. Contact closures A & B also can be triacs. A & B should both be closed for the triac source and open for triac sink.
- 10 For triac sink the common connection from the actuator must be connected to the hot connection of the controller. Position feedback cannot be used with a triac sink controller. The actuator internal common reference is not compatible.
- 12 IN4004 or IN4007 diode. (IN4007 supplied, Belimo part number 40155)
- 18 Actuators with plenum cable do not have numbers; use color codes instead.
- Meets cULus or UL and CSA Standard requirements without the need of an electrical ground connection.

WARNING Live Electrical Components!
During installation, testing, servicing and troubleshooting of this product, it may be necessary to work with live electrical components. Have a qualified licensed electrician or other individual who has been properly trained in handling live electrical components perform these tasks. Failure to follow all electrical safety precautions when exposed to live electrical components could result in death or serious injury.

P10401 - 01/13 - Subject to change. © Belimo Aircontrols (USA), Inc.

24 VAC Transformer

3 18

Blk (1) Common
Red (2) Hot ↑
Wht (3) Y Input ↓
Org (5) U Output

On/Off

24 VAC Transformer

2 10 18

Blk (1) - Common
Red (2) + Hot
Wht (3) Y, Input
Org (5) U Output 2 to 10V

Floating Point

24 VAC Transformer

3 18

Blk (1) Common
Red (2) + Hot
Wht (3) Y1 Input, 2 to 10V
Org (5) U Output, 2 to 10V

VDC/4-20 mA

24 VAC Transformer (AC Only)

18

Blk (1) Common
Red (2) + Hot
Wht (3) Y1 Input, 2 to 10V
Org (5)

Functions	a	b	c
Min*	0% ←	↘	↘
Mid*	50% ←	↘	↘
Max*	100% ←	↘	↘
Normal**	Control mode acc. to Y	↘	↘

* Default selectable 0-100%. See Configuration Data Sheet.
** Customizable. See Configuration Data Sheet.

Override