



Technical Data		
	G3	G3...(D)
Service	chilled or hot water, 60% glycol	
Flow characteristic	linear	
Action	stem up - open B to AB	stem up - open B to AB
Sizes	½" to 2"	
End fitting	NPT female ends	
Materials		
Body	bronze	
Seat	bronze	
Stem	stainless steel	
Plug	brass	
Packing	spring loaded TFE	
Disc	none	
ANSI class	ANSI 250 (up to 400 psi below 150°F)	
Leakage	ANSI III	
Media temperature water	20°F to 250°F (-7°C to 120°C)	
Maximum ΔP* water	35 psi (241 kPa)	
Rangeability	500:1	
Valve weights	G314, G315(D)	2 lbs
	G320	3 lbs
	G320D	2.5 lbs
	G325, G332(D)	2.5 lbs
	G325D	5 lbs
	G340(D), G350(D)	14 lbs

* (50% or more open)

G3...(D) 3-way Flow Patterns

G3 3-way Mixing Valve

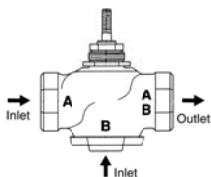

Stem Up - Open B to AB

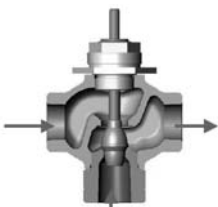

G3...(D) 3-way Diverting Valve

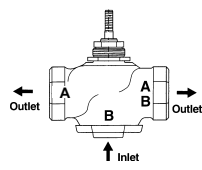

Stem Up - Open B to AB

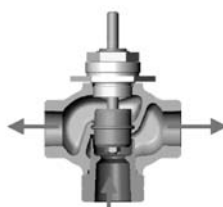

Note: Flow B to A travels through center of plug (as shown).

Application

This valve is typically used in Air Handling Units on heating or cooling coils and Fan Coil Unit heating or cooling coils. Some other common applications include Unit Ventilators, VAV Box reheat coils and bypass loops. This valve is suitable for use in a hydronic system with constant or variable flow.

3-way valves are available with mixing or diverting flow patterns.

Valve Nominal Size			Type	Suitable Actuators		
C _v	Inches	DN [mm]	3-way NPT	Non-Spring	Spring	
2.2	½	15	G314	LM Series	NV Series	LF Series
4.4	½	15	G315(D)			
7.5	¾	20	G320(D)			
14	1	25	G325(D)	NM	NF	NVF Series
20	1¼	32	G332(D)			
28	1½	40	G340(D)	AM Series	AF(X) Series	
41	2	50	G350			
40	2	50	G350(D)			

Dimensions

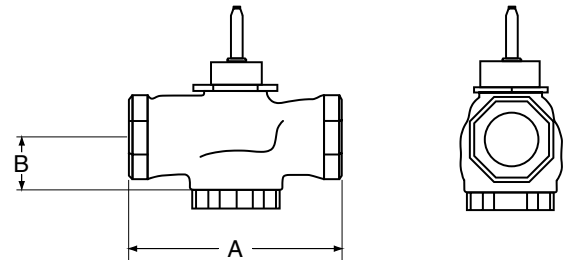

D078-3W

Valve Body	Valve Nominal Size		Dimensions (Inches [mm])	
	Inches	DN [mm]	A	B
G314	½"	15	3.06" [78]	1.37" [35]
G315(D)	½"	15	3.06" [78]	1.37" [35]
G320(D)	¾"	20	3.62" [92]	1.68" [43]
G325(D)	1"	25	4.62" [117]	1.56" [40]
G332(D)	1¼"	32	4.62" [117]	1.62" [41]
G340(D)	1½"	40	5.37" [137]	1.62" [41]
G350(D)	2"	50	6.12" [156]	1.87" [48]

Piping

The valves should be mounted in a weather-protected area in a location that is within the ambient limits of the actuator. Allow sufficient room for valve with actuator and for service. For the NV Series, allow 6" for cover removal and 12" for complete actuator removal. The G2(S) and G3(D) preferred mounting position of the valve is with the valve stem vertical above the valve body, for maximum life. However, the assemblies can be mounted with the valve stem vertical or horizontal in relation to the pipe. The actuators should never be mounted underneath the valve, as condensation can build up and result in a failure of the actuators. Do not reverse flow direction.

NFX24-MFT-X1 Actuators, Multi-Function Technology



Models

NFX24-MFT-X1
NFX24-MFT-S-X1

MFT



Technical Data	
Power supply	24 VAC ±20%, 50/60 Hz 24 VDC +20% / -10%
Power consumption ♦	running 6.5 W holding 3 W
Transformer sizing ♦	9 VA (Class 2 power source)
Electrical connection	3 ft [1m], 10 ft [3m] or 16 ft [5m] 18 GA appliance or plenum cables, with or without ½" conduit connector -S models: two 3 ft [1m], 10 ft [3m] or 16 ft [5m] appliance cables with or without ½" conduit connectors
Overload protection	electronic throughout 0 to 95° rotation
Operating range Y*	2 to 10 VDC, 4 to 20mA (default) variable (VDC, PWM, floating point, on/off)
Input impedance	100 kΩ for 2 to 10 VDC (0.1 mA) 500 Ω for 4 to 20 mA 1500 Ω for PWM, floating point, on/off
Feedback output U*	2 to 10 VDC (max. 0.5 mA)
Torque	90 in-lb [10 Nm] minimum
Direction of rotation*	spring motor reversible with CW/CCW mounting motor reversible with built-in switch
Mechanical angle of rotation*	95° (adjustable with mechanical end stop, 35° to 95°)
Running time	spring <20 seconds @ -4°F to 122°F [-20°C to 50°C]; <60 seconds @ -22°F [-30°C] motor* 150 seconds (default), variable (40 to 220 seconds)
Angle of rotation adaptation*	off (default)
Override control*	min position = 0% mid. position = 50% max. position = 100%
Position indication	visual indicator, 0° to 95° (0° is full spring return position)
Manual override	5 mm hex crank (⅜" Allen), supplied
Humidity	max. 95% RH non-condensing
Ambient temperature	-22°F to 122°F [-30°C to 50°C]
Housing	Nema 2, IP54, Enclosure Type2
Housing material	Zinc coated metal and plastic casing
Agency listings†	cULus acc. to UL60730-1A/-2-14, CAN/CSA E60730-1:02, CE acc. to 2004/108/EC & 2006/95/EC
Noise level	≤40dB(A) motor @ 150 secs, run time dependent ≤62dB(A) spring return
Quality standard	ISO 9001
Weight	4.2 lbs (1.9 kg), 4.3 lbs (2.0 kg) with switches

*Variable when configured with MFT options.

† Rated Impulse Voltage 800V, Type of action 1.AA (1.AA.B for -S version), Control Pollution Degree 3.

♦ Programmed for 40 sec motor run time. At 150 sec motor run time, transformer sizing is 6.5 VA and power consumption is 4.5 W running / 3 W holding.

NFX24-MFT-S-X1	
Auxiliary switches	2 x SPDT 3A (0.5A) @ 250 VAC, UL Approved one set at +10°, one adjustable 10° to 90°

Dimensions with G2...(S) Series 2-Way Valve

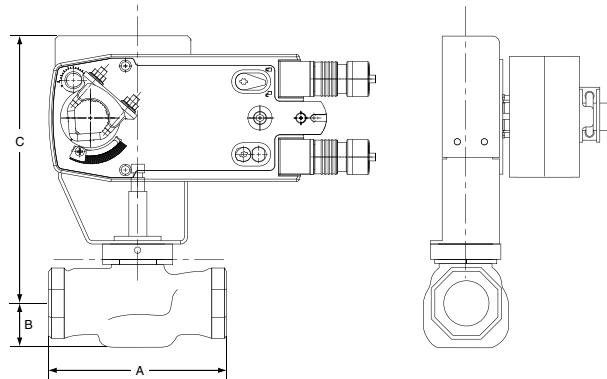

D180

Valve Body	Valve Nominal Size		Dimensions (Inches [mm])		
	Inches	DN [mm]	A	B	C
G2(S)	1"	32	4.62" [117]	1.12" [29]	8.12" [206]
G2(S)	1¼"	40	4.62" [117]	1.37" [35]	8.37" [213]

Dimensions with G3...(D) Series 3-Way Valve

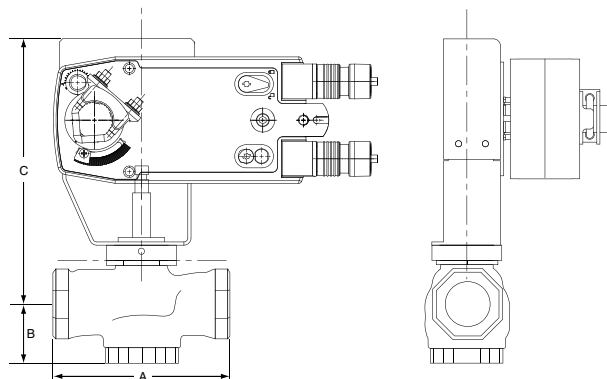

D185

Valve Body	Valve Nominal Size		Dimensions (Inches [mm])		
	Inches	DN [mm]	A	B	C
G3(D)	1"	25	4.62" [117]	1.56" [40]	8.56" [217]
G3(D)	1¼"	32	4.62" [117]	1.62" [41]	8.62" [219]

N40021 - 06/11 - Subject to change. © Belimo Aircontrols (USA), Inc.

Wiring Diagrams

INSTALLATION NOTES

- 1 Provide overload protection and disconnect as required.
- 2 **CAUTION Equipment Damage!**
Actuators may be connected in parallel if not mechanically mounted to the same shaft. Power consumption and input impedance must be observed.
- 3 Actuators may also be powered by 24 VDC.
- 4 Position feedback cannot be used with Triac sink controller.
- 5 The actuator internal common reference is not compatible.
- 6 Control signal may be pulsed from either the Hot (source) or the Common (sink) 24 VAC line.
- 7 Contact closures A & B also can be triacs.
- 8 A & B should both be closed for triac source and open for triac sink.
- 9 For triac sink the common connection from the actuator must be connected to the hot connection of the controller.

APPLICATION NOTES

Meets UL requirements without the need of an electrical ground connection.

The ZG-R01 500 Ω resistor may be used.

WARNING Live Electrical Components!
During installation, testing, servicing and troubleshooting of this product, it may be necessary to work with live electrical components. Have a qualified licensed electrician or other individual who has been properly trained in handling live electrical components perform these tasks. Failure to follow all electrical safety precautions when exposed to live electrical components could result in death or serious injury.

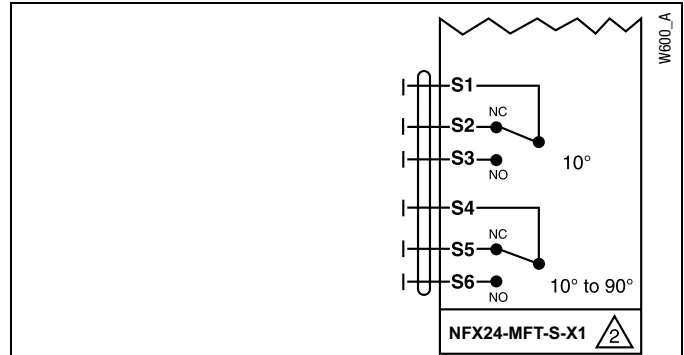

Auxiliary Switches for NFX24-MFT-S-X1

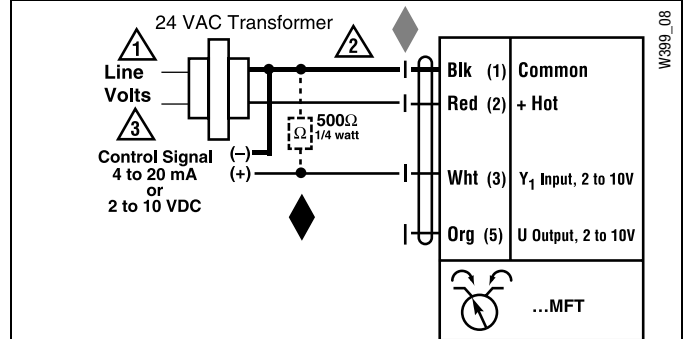

VDC/4-20 mA

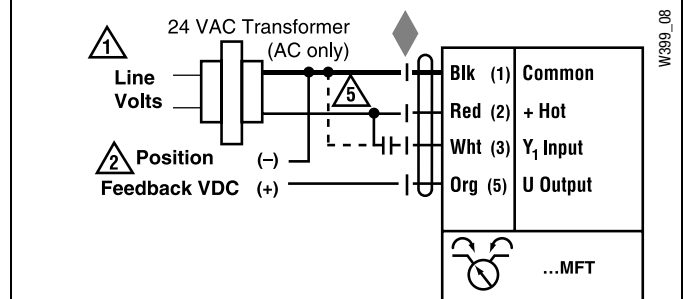

PWM

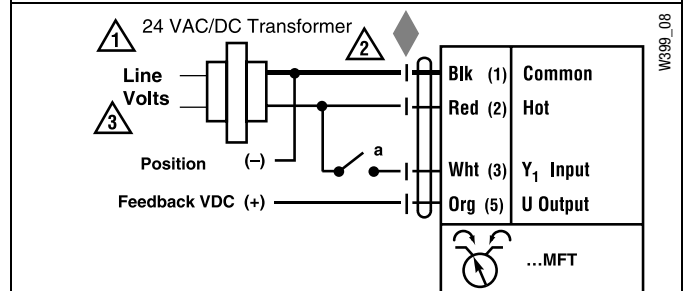

On/Off control

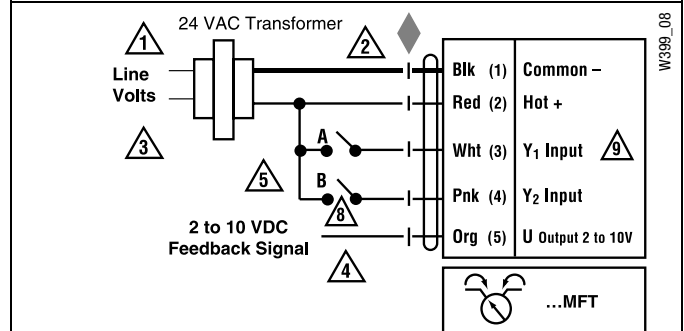

Floating Point control

	Non-Spring Return						Spring Return					
	NVD	NV	NVG	LM	NM	AM	NVFD	NVF	LF	NF	AF	AFX
2-way												
G212(S)	250			250			250		250			
G213(S)	250			250			250		250			
G214(S)	250			250			250		250			
G215(S)	250			250			250		250			
G219(S)	250			242			250		185			
G220(S)	250			242			250		185			
G224(S)		250			250			207		250		
G225(S)		250			250			207		250		
G232(S)		162			158			130		158		
G240(S)		110	160			230		88			169	230
G250(S)		58	190			127		47			93	127
3-way Mixing												
G314	250			250			250		250			
G315	250			250			250		250			
G320	250			242			250		185			
G325		250			250			207		250		
G332		162			158			130		158		
G340		110				230		88			169	230
G350		58				127		47			93	127
3-way Diverting												
G315D	250			250			250		250			
G320D	250			250			250		250			
G325D	250				250		250			250		
G332D		250			250			250		250		
G340D		250				250		250			250	250
G350D		250				250		250			250	250