

G6...C(S)(LCS) 2-way Pressure Compensated Flanged Globe Valve



Technical Data			
	G6...C	G6...CS	G6...LCS
Service	chilled or hot water, 60% glycol, steam	chilled or hot water, 60% glycol, steam	chilled or hot water, 60% glycol, steam
Flow characteristic	modified equal percentage		linear
Action	stem up - open A to AB		
Sizes	2½" to 6"		
End fitting	125 lb. flanged		
Materials			
Body	iron	iron	iron
Seat	bronze	stainless steel	stainless steel
Stem	stainless steel	stainless steel	stainless steel
Plug	bronze	stainless steel	stainless steel
Packing	NLP (no lip packing)	TFE V-ring	TFE V-ring
ANSI class	ANSI 125		
Leakage	Class III		
Max inlet			
Steam	35 psi (241kPa)	50 psi (340kPa) - NV	50 psi (340kPa) - NV
Steam- Rotary		100 psi (680kPa)	100 psi (680kPa)
Water	150 psi (1034kPa) @ 250°F	150 psi (1034kPa) @ 250°F	150 psi (1034kPa) @ 250°F
Media temperature			
Water	32°F to 300°F (0°C to 148°C)	32°F to 350°F (0°C to 176°C)	32°F to 350°F (0°C to 176°C)
Steam	32°F to 280°F (0°C to 138°C)	32°F to 338°F (0°C to 170°C)	32°F to 338°F (0°C to 170°C)
Maximum ΔP*			
Water	25 psi (172kPa)	50 psi (340kPa)	50 psi (340kPa)
Steam	15 psi (103kPa)	50 psi (340kPa)	50 psi (340kPa)
Rangeability	G665C 85:1 G680C 91:1	G6100C 98:1 G6125C 100:1	G6150C 98:1

* (50% or more open)

G6...C(S) 2-way Flow Patterns

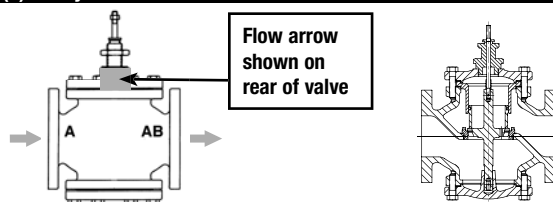

Flow Pattern is marked on valve.

Stem Up - Open A to AB

Application

This valve is typically used in Large Air Handling Units on heating or cooling coils. This valve is suitable for use in a hydronic system with variable flow.

Bronze or stainless steel trim valves can be used for steam applications, depending on actuator and close-off combination.

C _v	Valve Nominal Size		Suitable Actuators		
	Inches	Type	Non-Spring	Spring	Electronic Fail-Safe
65	2½	G665C(S)	NV	AF(X) Series	GK Series
90	3	G680C(S)			
170	4	G6100C(S)	GM Series		
263	5	G6125C(S)			
344	6	G6150C(S)			
65	2½	G665LCS	NV		
90	3	G680LCS			
170	4	G6100LCS	GM Series	GK Series	
263	5	G6125LCS			
344	6	G6150LCS			

Dimensions

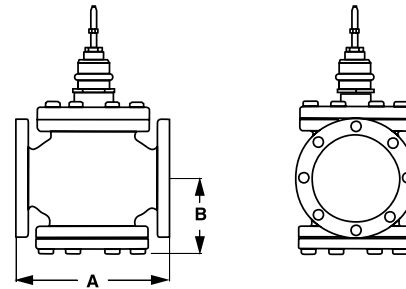

D166 2/1F

Valve Body	Valve Nominal Size		Dimensions (Inches [mm])	
	Inches	DN [mm]	A	B
G665C(S)	2½"	[65]	9" [229]	4.75" [120]
G680C(S)	3"	[80]	10" [254]	5.37" [137]
G6100C(S)	4"	[100]	13" [330]	6.87" [175]
G6125C(S)	5"	[125]	15.75" [400]	7.87" [200]
G6150C(S)	6"	[150]	17.75" [757]	8.50" [216]
G665LCS	2½"	[65]	9" [229]	4.75" [120]
G680LCS	3"	[80]	10" [254]	5.37" [137]
G6100LCS	4"	[100]	13" [330]	6.87" [175]
G6125LCS	5"	[125]	15.75" [400]	7.87" [200]
G6150LCS	6"	[150]	17.75" [757]	8.50" [216]

Piping

The valves should be mounted in a weather-protected area in a location that is within the ambient limits of the actuator. Allow sufficient room for valve with actuator and for service. For the NV Series, allow 6" for cover removal and 12" for complete actuator removal. The G6/G7 preferred mounting position of the valve is with the valve stem vertical above the valve body, for maximum life. However, the assemblies can be mounted with valve stem vertical above the valve or up to 45 degrees in relation to the horizontal pipe. The actuators should never be mounted underneath the valve, as condensation can build up and result in a failure of the actuators. Do not reverse flow direction.

M40026 - 07/10 - Subject to change. © Belimo Aircontrols (USA), Inc.



Models

GKX24-MFT-X1

Technical Data	
Power Supply	24VAC \pm 20% 50/60Hz 24VDC \pm 10%
Power Consumption	15W (1.5W)
Transformer Sizing	20VA (Class2 power source)
Electrical Connection	18 GA plenum rated Cable ½" conduit connector Protected NEMA 2 (IP54)
Overload Protection	Electronic throughout 0 to 95 rotation
Operation range Y	2 to 10 VDC, 4 to 20mA (default) Variable (VDC,PWM, Floating point, On/Off)
Input Impedance	100k Ω (0.1 mA), 500 Ω 1500 Ω (PWM, Floating point, On/Off)
Feedback Output U	2 to 10VDC, 0.5mA max VDC variable
Angle of rotation	Max. 95°, adjust. with mechanical Stop electronically variable
Torque	360 in-lb [40Nm]
Direction of rotation	Reversible with switch
Fails save position	Adjustable with dial or tool 0 to 100% in 10% increments
Position indication	Reflective visual indicator (snap-on)
Manual override	External push button
Running time normal operation	95 seconds (default), variable 90 to 150s
Running time fail safe	35 seconds
Humidity	5 to 95% RH non-condensing (EN 60730-1)
Ambient temperature	-22°F to +122°F [-30°C to +50°C]
Storage temperature	-40°F to +176°F [-40°C to +80°C]
Housing	NEMA2, IP54, UL enclosure type 2
Housing Material	UL94-5VA
Agency List	cULus acc. to UL 60730-1A/-2-14 CAN/CSA E60730-1:02 CE acc. to 2004/108/EEC and 2006/95/EC
Noise Level	<45dB(A) at 90s
Quality Standard	ISO 9001
Weight	3.85 lbs [1.75 kg]

Dimensions with G6/G6C ANSI 125 and G6 ANSI 250 Series 2-Way Valve

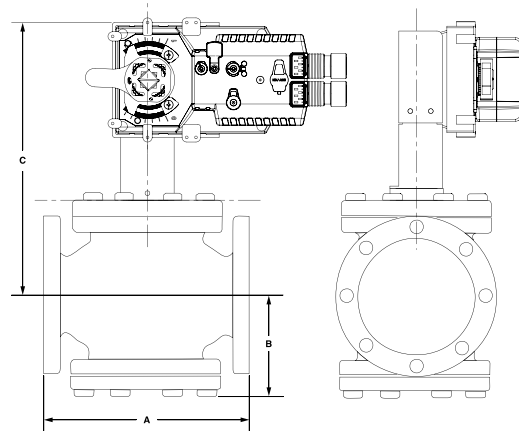

Valve Body	Valve Nominal Size		Dimensions (Inches [mm])		
	Inches	DN [mm]	A	B	C
G6 ANSI 125	2½"	65	9.00" [229]	4.75" [121]	13.50" [343]
G6 ANSI 125	3"	80	10.00" [254]	5.37" [136]	13.94" [354]
G6 ANSI 250	2½"	65	9.62" [244]	4.75" [121]	14.00" [356]
G6 ANSI 250	3"	80	10.75" [273]	5.37" [136]	14.12" [359]
G6C ANSI 125	4"	100	13.00" [330.2]	6.87" [175]	15.50" [394]
G6C ANSI 125	5"	125	15.75" [400]	7.87" [200]	16.12" [410]
G6C ANSI 125	6"	150	17.75" [451]	8.50" [216]	16.75" [425]

Dimensions with G7 and G7D ANSI 125/250 Series 3-Way Valve

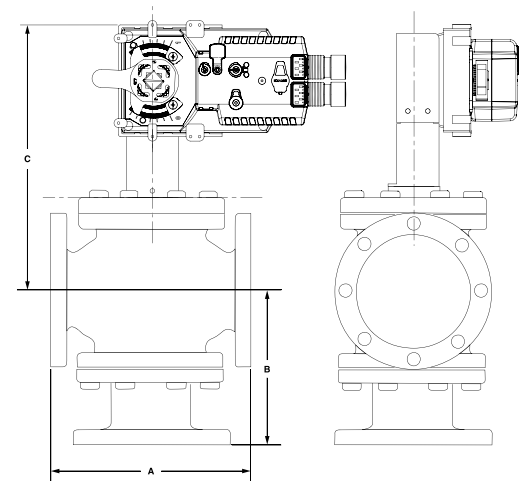

Valve Body	Valve Nominal Size		Dimensions (Inches [mm])		
	Inches	DN [mm]	A	B	C
G7 & G7D ANSI 125	2½"	65	9.00" [229]	7.12" [181]	13.62" [346]
G7 & G7D ANSI 125	3"	80	10.00" [254]	8.00" [203]	14.43" [367]
G7 & G7D ANSI 125	4"	100	13.00" [330]	9.87" [251]	15.50" [394]
G7D ANSI 125	5"	125	12.00" [305]	10.50" [267]	15.81" [402]
G7D ANSI 125	6"	150	14.12" [359]	11.12" [283]	16.50" [419]
G7 & G7D ANSI 250	2½"	65	9.62" [244]	7.37" [187]	14.00" [356]
G7 & G7D ANSI 250	3"	80	10.75" [273]	8.37" [213]	14.62" [371]
G7 & G7D ANSI 250	4"	100	13.62" [346]	10.25" [260]	15.62" [397]
G7D ANSI 250	5"	125	12.87" [327]	11.00" [279]	11.00" [279]
G7D ANSI 250	6"	150	14.50" [368]	11.50" [292]	11.50" [292]

M40026 - 07/10 - Subject to change. © Belimo Aircontrols (USA), Inc.

Wiring Diagrams

INSTALLATION NOTES

- 1 Provide overload protection and disconnect as required.
- 2 **CAUTION Equipment Damage!**
Actuators may be connected in parallel if not mechanically mounted to the same shaft. Power consumption and input impedance must be observed.
- 3 Actuators may also be powered by 24 VDC.
- 4 Position feedback cannot be used with Triac sink controller. The actuator internal common reference is not compatible.
- 5 Control signal may be pulsed from either the Hot (source) or the Common (sink) 24 VAC line.
- 8 Contact closures A & B also can be triacs.
- 9 For triac sink the common connection from the actuator must be connected to the hot connection of the controller.

APPLICATION NOTES

- WARNING Live Electrical Components!**
During installation, testing, servicing and troubleshooting of this product, it may be necessary to work with live electrical components. Have a qualified licensed electrician or other individual who has been properly trained in handling live electrical components perform these tasks. Failure to follow all electrical safety precautions when exposed to live electrical components could result in death or serious injury.

Operations

Setting the Fail-Safe Position

Belimo's new Electronic Fail-Safe Actuators allows the user to set the fail position (0-100% in 10% increments). To set the position of the fail-safe, rotate the cover away from the fail-safe switch. Turn the switch to the desired position. To set with PC Tool, turn the switch to PROG FAIL-SAFE. When done, rotate the cover back into position.

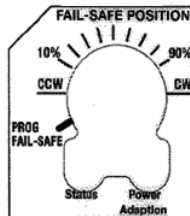

Note: If switch is left in PROG FAIL-SAFE, the PC Tool software setting is active and can set the fail-safe position. It is recommended that the switch be set on the front of the actuator. This gives a simple visual as to what the fail-safe position is set as. If the fail-safe is programmed using the PC Tool, and the switch is then moved off the PROG FAIL-SAFE position, the new position will override the PC Tool setting. The direction switch does not affect the fail-safe position switch.

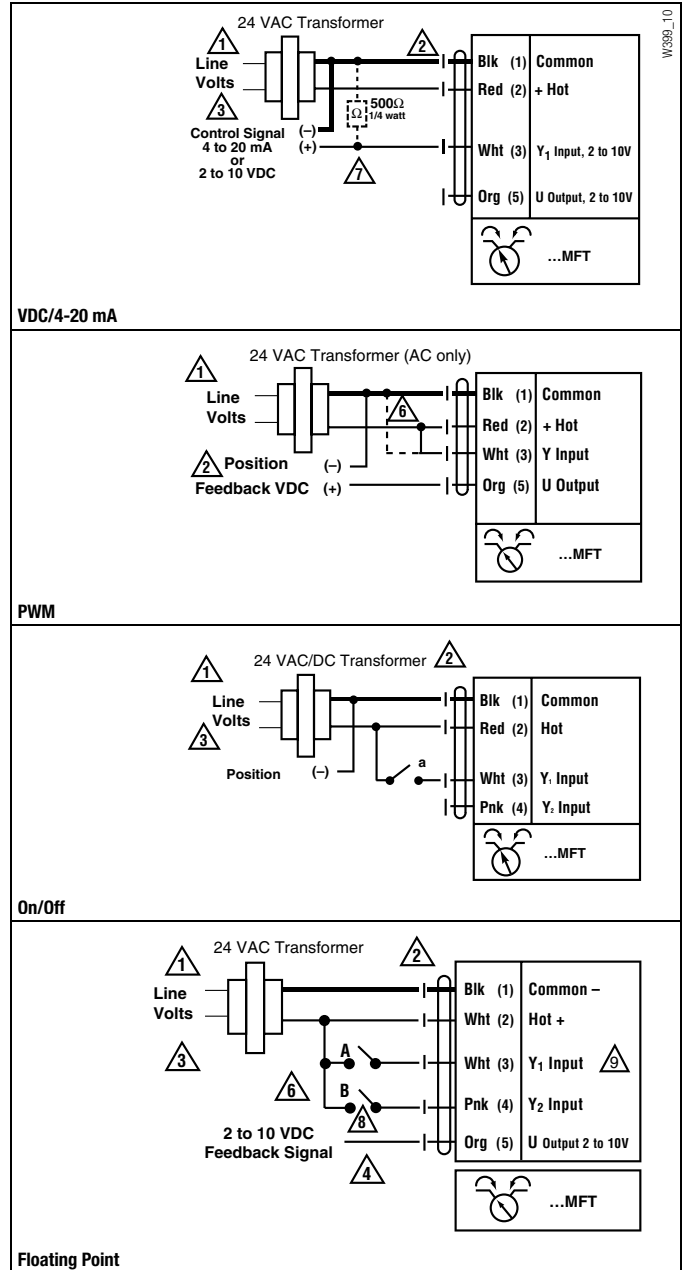

	Non-Spring Return				Spring Return					Electronic Fail-Safe
	NV	NVG	GM	2 x GM	NVF	AF	2x AF	AFX	2 x AFX	GK
2-way ANSI 125										
G665, G665S		62	113	150		36	59	51	82	113
G680, G680S		42	78	121		24	40	34	56	78
2-way Pressure Comp										
G665C, G665CS, G665LCS	150				150	150		150		
G680C, G680CS, G680LCS	150				136	150		150		
G6100C, G6100CS, G6100LCS			150				132		150	150
G6125C, G6125CS, G6125LCS			150				87		150	150
G6150C, G6150CS, G6150LCS			150				50		150	150
2-way ANSI 250										
G665-250, G665S-250		62	113	176		36	59	51	82	113
G680-250, G680S-250		42	78	121		24	40	34	56	78
3-way ANSI 125 Mixing										
G765, G765S		62	113	150		36	59	51	82	114
G780, G780S		42	78	121		24	40	34	56	78
G7100, G7100S			19	31					13	19
G7125, G7125S				19						
G7150, G7150S				13						
3-way ANSI 250 Mixing										
G765-250, G765S-250		62	113	176		35	58	40	114	114
G780-250, G780S-250		42	78	121		23	40	25	77	78
G7100-250, G7100S-250				31					24	19
G7125-250, G7125S-250				19						
G7150-250, G7150S-250				13						
3-way ANSI 125/250 Diverting										
G765D, G765DS, G765DS-250		100	100			100		100		100
G780D, G780DS, G780DS-250		100	100			100		100		100
G7100D, G7100DS, G7100DS-250		100	100			100		100		100
G7125D, G7125DS, G7125DS-250			100				100		100	100
G7150D, G7150DS, G7150DS-250			100				100		100	100

M40026 - 07/10 - Subject to change. © Belimo Aircontrols (USA), Inc.