

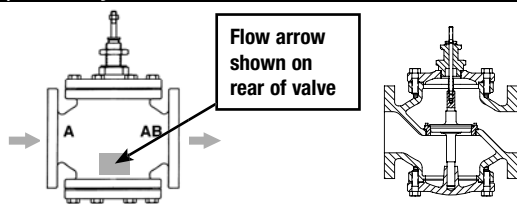

Technical Data		
	G6...-250	G6...S-250
Service	chilled or hot water, 60% glycol, steam	chilled or hot water, 60% glycol, steam
Flow characteristic	modified equal percentage	
Action	stem up - open A to AB	
Sizes	2½" to 3"	
End fitting	250 lb. flanged	
Materials		
Body	iron	iron
Seat	bronze	stainless steel
Stem	stainless steel	stainless steel
Plug	bronze	stainless steel
Packing	NLP (no lip packing)	TFE V-ring
ANSI class	ANSI 250	
Leakage	Class III	
Max inlet		
Steam	35 psi (241kPa)	50 psi (345kPa)- NV 100 psi (680kPa)- Rotary
Water	250 psi (1724kPa) @ 350°F	250 psi (1724kPa) @ 350°F
Media temperature		
Water	32°F to 350°F (0°C to 176°C)	32°F to 350°F (0°C to 176°C)
Steam	32°F to 280°F (0°C to 138°C)	32°F to 298°F - NV (0°C to 148°C) 32°F to 338°F - Rotary (0°C to 170°C)
Maximum ΔP*		
Water	25 psi (172kPa)	50 psi (340kPa)
Steam	15 psi (103kPa)	50 psi (340kPa)
Rangeability	50:1	
Valve weights	G665(S)-250 G680(S)-250 G6100(S)-250	64 lbs 77 lbs 131 lbs

* (50% or more open)

G6...(S)-250 2-way Flow Patterns



Flow Pattern is marked on valve.

Stem Up - Open A to AB

Application

This valve is typically used in Large Air Handling Units on heating or cooling coils. This valve is suitable for use in a hydronic system with variable flow.

Valves are designed for ANSI 250 piping systems. Bronze or stainless steel trim valves can be used for higher pressure steam applications, depending on actuator and close-off combination.

Valve Nominal Size	Type	Suitable Actuators			Electronic Fail-Safe
		Non-Spring	Spring		
C _v	Inches	2-way Flanged	Non-Spring	Spring	
65	2½	G665(S)-250	NVG	GM	AF
90	3	G680(S)-250			APX
170	4	G6100(S)-250			GK

Dimensions

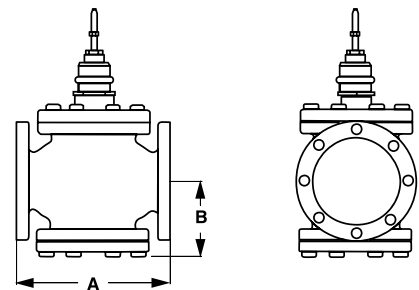

Valve Body	Valve Nominal Size		Dimensions (Inches [mm])	
	Inches	DN [mm]	A	B
G665(S)-250	2½"	[65]	9.63" [245]	4.75" [120]
G680(S)-250	3"	[80]	10.75" [273]	5.37" [137]
G6100(S)-250	4"	[100]	13.62" [346]	6.37" [162]

Piping

The valves should be mounted in a weather-protected area in a location that is within the ambient limits of the actuator. Allow sufficient room for valve with actuator and for service. For the NV Series, allow 6" for cover removal and 12" for complete actuator removal. The G6/G7 preferred mounting position of the valve is with the valve stem vertical above the valve body, for maximum life. However, the assemblies can be mounted with valve stem vertical above the valve or up to 45 degrees in relation to the horizontal pipe. The actuators should never be mounted underneath the valve, as condensation can build up and result in a failure of the actuators. Do not reverse flow direction.

AF24(-S) US Actuators, On/Off



Models

AF24 US
AF24-S US w/built-in Aux. Switches

Technical Data		
Control		on/off
Power supply		24 VAC ± 20% 50/60 Hz 24 VDC ± 10%
Power consumption	running	5 W
	holding	1.5 W
Transformer sizing		10 VA (Class 2 power)
Electrical connection		3 ft, 18 GA appliance cables (-S model has 2 cables) ½" conduit connector
Electrical protection		auxiliary switches are double insulated
Overload protection		electronic throughout 0° to 95° rotation
Angle of rotation		95°
Position indication		visual indicator, 0° to 95°
Manual override		hex crank
Running time	control	150 seconds independent of load
	spring	< 20 seconds
Ambient temperature		-22° F to 122° F [-30° C to 50° C]
Housing		NEMA 2 / IP54
Agency listings		UL 873, CSA C22.2 No. 24 certified, CE
Noise level		max. 45 dB(A)

AF24-S US		
Auxiliary switches		2 x SPDT, 7A (2.5A) @ 250 VAC, UL listed, one switch is fixed at +5°, one is adjustable 25° to 85° (double insulated)

Dimensions with G2...(S) Series 2-Way Valve

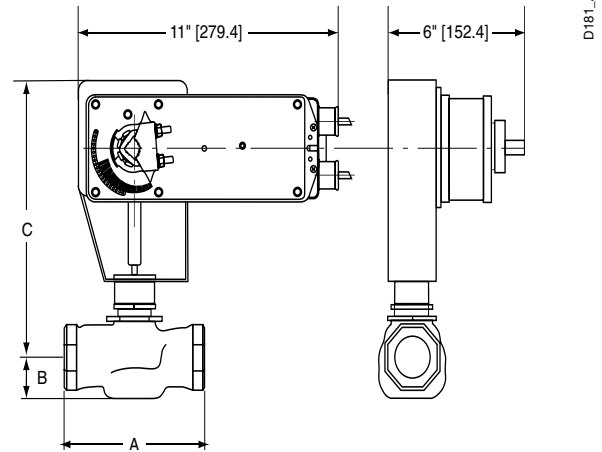

Valve Nominal Size			Dimensions (Inches [mm])		
Valve Body	Inches	DN [mm]	A	B	C
G2(S)	1½"	40	5.37" [137]	1.50" [38]	8.50" [216]
G2(S)	2"	50	6.12" [156]	1.56" [40]	8.56" [217]

Dimensions with G3...(D) Series 3-Way Valve

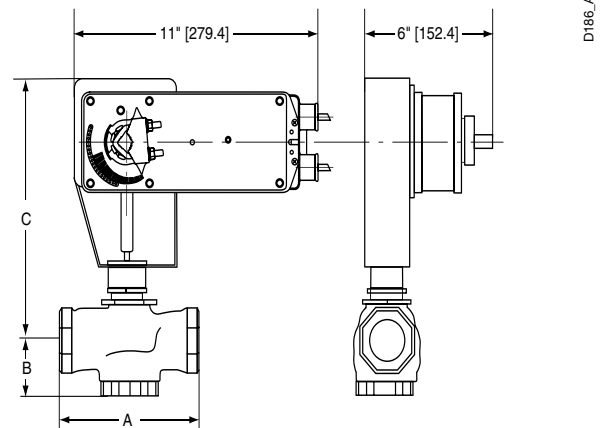

Valve Nominal Size			Dimensions (Inches [mm])		
Valve Body	Inches	DN [mm]	A	B	C
G3(D)	1½"	40	5.37" [137]	1.62" [41]	8.62" [219]
G3(D)	2"	50	6.12" [156]	1.87" [48]	8.87" [225]

N40021 - 06/11 - Subject to change. © Belimo Aircontrols (USA), Inc.

Dimensions with G6/G6C ANSI 125 and G6 ANSI 250 Series 2-Way Valve

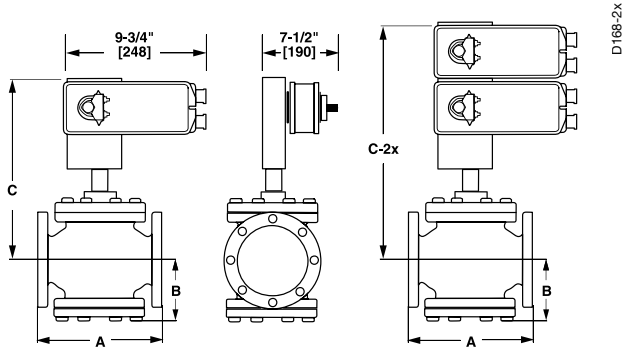

Valve Body	Valve Nominal Size		Dimensions (Inches [mm])		
	Inches	DN [mm]	A	B	C
G6 ANSI 125	2½"	65	9.00" [229]	4.75" [121]	13.50" [343]
G6 ANSI 125	3"	80	10.00" [254]	5.37" [136]	13.94" [354]
G6 ANSI 250	2½"	65	9.62" [244]	4.75" [121]	14.00" [356]
G6 ANSI 250	3"	80	10.75" [273]	5.37" [136]	14.12" [359]
G6C ANSI 125	2½"	65	9.00" [229]	4.75" [121]	13.50" [343]
G6C ANSI 125	3"	80	10.00" [254]	5.37" [136]	13.94" [354]

Valve Body	Valve Nominal Size		Dimensions (Inches [mm])		
	Inches	DN [mm]	A	B	C-2x
G6 ANSI 125	2½"	65	9.00" [229]	4.75" [121]	18.25" [464]
G6 ANSI 125	3"	80	10.00" [254]	5.37" [136]	19.18" [487]
G6 ANSI 250	2½"	65	9.62" [244]	4.75" [121]	18.75" [476]
G6 ANSI 250	3"	80	10.75" [273]	5.37" [136]	19.75" [502]
G6C ANSI 125	4"	100	13.00" [330.2]	6.87" [175]	20.25" [514]
G6C ANSI 125	5"	125	15.75" [400]	7.87" [200]	20.87" [530]
G6C ANSI 125	6"	150	17.75" [451]	8.50" [216]	21.50" [546]

Dimensions with G7/G7D ANSI 125/250 Series 3-Way Valve

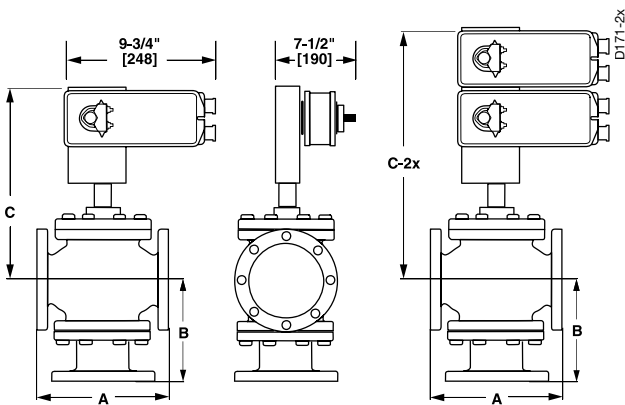

Valve Body	Valve Nominal Size		Dimensions (Inches [mm])		
	Inches	DN [mm]	A	B	C
G7 & G7D ANSI 125	2½"	65	9.00" [229]	7.12" [181]	13.87" [352]
G7 & G7D ANSI 125	3"	80	10.00" [254]	8.00" [203]	14.44" [367]
G7D ANSI 125	4"	100	13.00" [330.2]	9.87" [251]	15.25" [387]
G7 & G7D ANSI 250	2½"	65	9.62" [244]	7.37" [187]	14.00" [356]
G7 & G7D ANSI 250	3"	80	10.75" [273]	8.37" [213]	14.62" [371]
G7D ANSI 250	4"	100	13.62" [346]	10.25" [260]	15.25" [387]

Dimensions with G7/G7D ANSI 125/250 Series 3-Way Valve

Valve Body	Valve Nominal Size		Dimensions (Inches [mm])		
	Inches	DN [mm]	A	B	C-2x
G7 ANSI 125	2½"	65	9.00" [229]	7.12" [181]	18.37" [467]
G7 ANSI 125	3"	80	10.00" [254]	8.00" [203]	19.18" [487]
G7D ANSI 125	5"	125	12.00" [305]	10.50" [267]	20.56" [522]
G7D ANSI 125	6"	150	14.12" [359]	11.12" [282]	21.25" [540]
G7 ANSI 250	2½"	65	9.62" [244]	7.37" [187]	18.75" [476]
G7 ANSI 250	3"	80	10.75" [273]	8.37" [213]	19.37" [492]
G7D ANSI 250	5"	125	12.87" [327]	11.00" [279]	20.56" [522]
G7D ANSI 250	6"	150	14.50" [368]	11.50" [292]	21.25" [540]

Wiring Diagrams

INSTALLATION NOTES

- CAUTION Equipment damage!**
Actuators may be connected in parallel. Power consumption must be observed.
- Actuators may also be powered by 24 VDC.
- Actuators with plenum rated cable do not have numbers on wires; use color codes instead. Actuators with appliance cables are numbered.

APPLICATION NOTES

- Meets cULus or UL and CSA requirements without the need of an electrical ground connection.

WARNING Live Electrical Components!
During installation, testing, servicing and troubleshooting of this product, it may be necessary to work with live electrical components. Have a qualified licensed electrician or other individual who has been properly trained in handling live electrical components perform these tasks. Failure to follow all electrical safety precautions when exposed to live electrical components could result in death or serious injury.

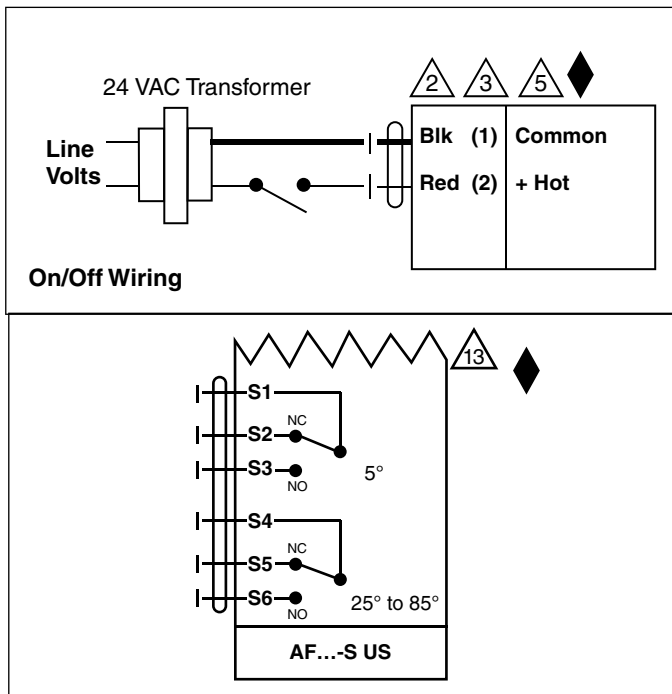

Auxiliary Switch Wiring for AF... -S US

Wiring Diagrams for Multiple On/Off Actuators

- Provide overload protection and disconnect as required..
- Actuators may be connected in parallel. Power consumption must be observed.
- Actuators may also be powered by 24 VDC.
- Same model numbers must be used when mounted on one shaft..

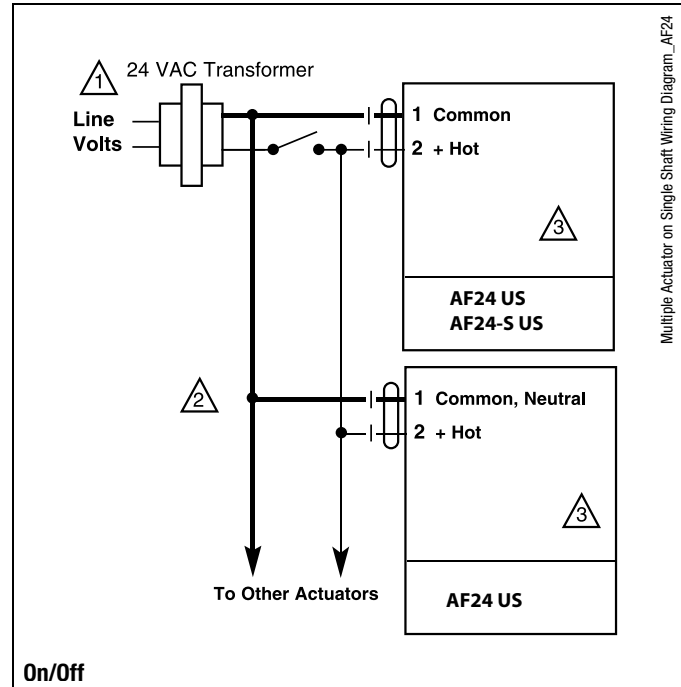

	Non-Spring Return				Spring Return					Electronic Fail-Safe
	NV	NVG	GM	2 x GM	NVF	AF	2x AF	AFX	2 x AFX	GK
2-way ANSI 125										
G665, G665S		62	113	150		36	59	51	82	113
G680, G680S		42	78	121		24	40	34	56	78
G6100, G6100S			19							19
2-way Pressure Comp ANSI 125										
G665C, G665CS, G665LCS	150				150	150		150		
G680C, G680CS, G680LCS	150				136	150		150		
G6100C, G6100CS, G6100LCS			150				132		150	150
G6125C, G6125CS, G6125LCS			150				87		150	150
G6150C, G6150CS, G6150LCS			150				50		150	150
2-way Pressure Comp ANSI 250										
G665C-250, G665CS-250								250		
G680C-250, G680CS-250								250		
G6100C-250, G6100CS-250			250						212	250
G6125C-250, G6125CS-250			239						152	239
G6150C-250, G6150CS-250			178						105	178
2-way ANSI 250										
G665-250, G665S-250		62	113	176		36	59	51	82	113
G680-250, G680S-250		42	78	121		24	40	34	56	78
G6100-250, G6100S-250			19							19
3-way ANSI 125 Mixing										
G765, G765S		62	113	150		36	59	51	82	114
G780, G780S		42	78	121		24	40	34	56	78
G7100, G7100S			19	31					13	19
G7125, G7125S				19						
G7150, G7150S				13						
3-way ANSI 250 Mixing										
G765-250, G765S-250		62	113	176		35	58	40	114	114
G780-250, G780S-250		42	78	121		23	40	25	77	78
G7100-250, G7100S-250				31					24	19
G7125-250, G7125S-250				19						
G7150-250, G7150S-250				13						
3-way ANSI 125/250 Diverting										
G765D, G765DS, G765DS-250		100	100			100		100		100
G780D, G780DS, G780DS-250		100	100			100		100		100
G7100D, G7100DS, G100DS-250		100	100			100		100		100
G7125D, G7125DS, G7125DS-250			100				100		100	100
G7150D, G7150DS, G7150DS-250			100				100		100	100