



Technical Data		
	G7...D	G7...DS
Service	chilled or hot water, 60% glycol	chilled or hot water, 60% glycol
Flow characteristic	linear	
Action	stem up - open AB to B	
Sizes	2½" to 6"	
End fitting	125 lb. flanged	
Materials		
Body	iron	iron
Seat	bronze	stainless steel
Stem	stainless steel	stainless steel
Plug	bronze	stainless steel
Packing	NLP (no lip packing)	TFE V-ring
ANSI class	ANSI 125	
Leakage	ANSI Class III	
Max inlet		
Water	150 psi (1034kPa) @ 250°F	
Media temperature		
Water	32°F to 300°F (0°C to 148°C)	
Maximum ΔP*		
Water	25 psi (172kPa)	50 psi (340kPa)
Rangeability	50:1	

\* (50% or more open)

## Application

This valve is typically used in Large Air Handling Units on heating or cooling coils. This valve is suitable for use in a hydronic system with variable flow.

These valves are to be used in Diverting applications only.

C <sub>v</sub>	Valve Nominal Size		Suitable Actuators		
	Inches	Type	Non-Spring	Spring	Electronic Fail-Safe
68	2½	G765D(S)	NVG	GM Series	GK Series
85	3	G780D(S)			
154	4	G7100D(S)			
195	5	G7125D(S)		AF(X) Series	
248	6	G7150D(S)			

## Dimensions

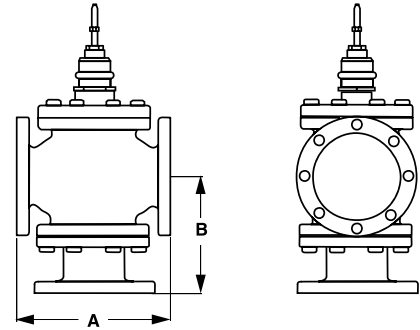

D168-G73W

Valve Body	Valve Nominal Size		Dimensions (Inches [mm])	
	Inches	DN [mm]	A	B
G765D(S)	2½"	[65]	9.00" [229]	7.12" [181]
G780D(S)	3"	[80]	10.00" [254]	8.00" [203]
G7100D(S)	4"	[100]	13.00" [330]	9.87" [251]
G7125D(S)	5"	[125]	12.00" [305]	10.50" [267]
G7150D(S)	6"	[150]	14.13" [359]	11.13" [283]

## G7...D(S) 3-way Flow Patterns

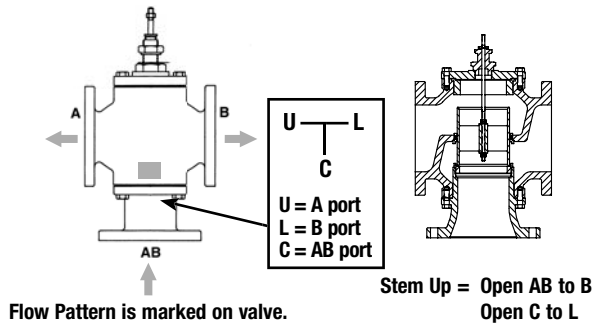

## Piping

The valves should be mounted in a weather-protected area in a location that is within the ambient limits of the actuator. Allow sufficient room for valve with actuator and for service. For the NV Series, allow 6" for cover removal and 12" for complete actuator removal. The G6/G7 preferred mounting position of the valve is with the valve stem vertical above the valve body, for maximum life. However, the assemblies can be mounted with valve stem vertical above the valve or up to 45 degrees in relation to the horizontal pipe. The actuators should never be mounted underneath the valve, as condensation can build up and result in a failure of the actuators. Do not reverse flow direction.

# GMB24-3-X1 Actuators, On/Off, Floating Point



## Models

GMB24-3-X1  
2xGMB24-3-X1

Technical Data	
Power supply	24 VAC ± 20% 50/60 Hz 24 VDC ± 10%
Power consumption	running 4 W holding 2 W
Transformer sizing	6 VA (Class 2 power source)
Electrical connection	□ 3 ft [1m] 18 GA plenum rated cable ½" conduit connector
Overload protection	electronic throughout stroke
Control	On/Off, Floating Point
Angle of rotation	95°
Direction of rotation	reversible with  switch
Position indication	reflective visual indicator (snap-on)
Running time	150 seconds, constant independent of load
Humidity	5 to 95% RH non-condensing
Ambient temperature	-22°F to 122°F [-30°C to 50°C]
Housing	NEMA 2/IP54 with cable entry down
Housing material	UL94-5V (flammability rating)
Agency listings	dULus acc. to UL 60730-1A/-2-14, CAN/CSA E60730-1, CSA C22.2 No. 24-93, CE acc. to 89/336/EEC
Noise level	<45 dB(A)
Quality standard	ISO 9001

## Dimensions with G6/G6C ANSI 125 and G6 ANSI 250 Series 2-Way Valve

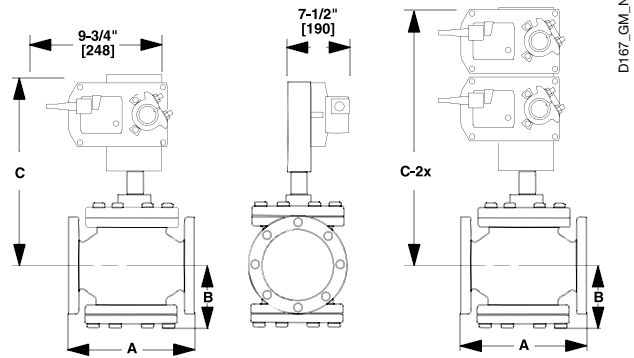

### Valve Nominal Size

Valve Body	Inches	DN [mm]	A	B	C
G6 ANSI 125	2½"	65	9.00" [229]	4.75" [121]	13.50" [343]
G6 ANSI 125	3"	80	10.00" [254]	5.37" [136]	13.93" [355]
G6 ANSI 250	2½"	65	9.62" [244]	4.75" [121]	13.50" [343]
G6 ANSI 250	3"	80	10.75" [273]	5.37" [136]	13.93" [355]
G6C ANSI 125	4"	100	13.00" [330.2]	6.87" [175]	15.50" [394]
G6C ANSI 125	5"	125	15.75" [400]	7.87" [200]	16.12" [410]
G6C ANSI 125	6"	150	17.75" [451]	8.50" [216]	16.75" [425]

### Valve Nominal Size

Valve Body	Inches	DN [mm]	A	B	C-2x
G6 ANSI 125	2½"	65	9.00" [229]	4.75" [121]	18.25" [464]
G6 ANSI 125	3"	80	10.00" [254]	5.37" [136]	19.18" [487]
G6 ANSI 250	2½"	65	9.62" [244]	4.75" [121]	18.25" [464]
G6 ANSI 250	3"	80	10.75" [273]	5.37" [136]	19.18" [487]

M40026 - 07/10 - Subject to change. © Belimo Aircontrols (USA), Inc.

### Dimensions with G7 and G7D ANSI 125/250 Series 3-Way Valve

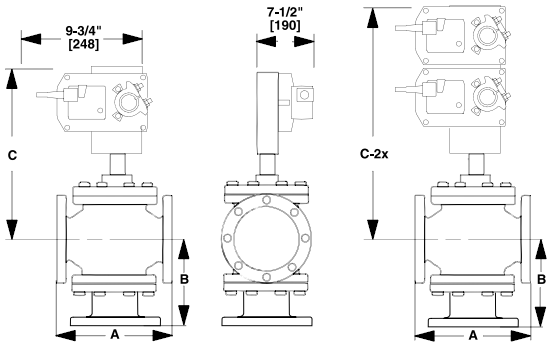

D167\_GM\_NG\_3\_2010

Valve Body	Valve Nominal Size		Dimensions (Inches [mm])		
	Inches	DN [mm]	A	B	C
G7 & G7D ANSI 125	2-1/2"	65	9.00" [229]	7.12" [181]	13.87" [352]
G7 & G7D ANSI 125	3"	80	10.00" [254]	8.00" [203]	14.43" [367]
G7 & G7D ANSI 125	4"	100	13.00" [330]	9.87" [251]	15.50" [394]
G7D ANSI 125	5"	125	12.00" [305]	10.50" [267]	14.12" [359]
G7D ANSI 125	6"	150	14.12" [359]	11.12" [282]	15.12" [505]
G7 & G7D ANSI 250	2-1/2"	65	9.62" [244]	7.37" [187]	13.87" [352]
G7 & G7D ANSI 250	3"	80	10.75" [273]	8.37" [213]	14.43" [367]
G7 & G7D ANSI 250	4"	100	13.62" [346]	10.25" [260]	15.50" [394]
G7D ANSI 250	5"	125	12.87" [327]	11.00" [279]	14.12" [359]
G7D ANSI 250	6"	150	14.50" [368]	11.50" [292]	15.12" [505]

Valve Body	Valve Nominal Size		Dimensions (Inches [mm])		
	Inches	DN [mm]	A	B	C-2x
G7 ANSI 125	2-1/2"	65	9.00" [229]	7.12" [181]	18.62 [473]
G7 ANSI 125	3"	80	10.00" [254]	8.00" [203]	19.18 [487]
G7 ANSI 125	4"	100	13.00" [330.2]	9.87" [251]	20.25 [514]
G7 ANSI 125	5"	125	15.75" [400]	9.25" [235]	18.87 [480]
G7 ANSI 125	6"	150	17.75" [451]	9.87" [251]	19.87 [505]
G7 ANSI 250	2-1/2"	65	9.62" [244]	7.37" [187]	18.75 [476]
G7 ANSI 250	3"	80	10.75" [273]	8.37" [213]	19.37 [492]
G7 ANSI 250	4"	100	13.62" [346]	10.25" [260]	20.37 [517]
G7 ANSI 250	5"	125	16.62" [422]	10.37" [264]	19.25 [489]
G7 ANSI 250	6"	150	18.62" [473]	11.00" [279]	19.75 [502]

### Wiring Diagrams

- 1 Provide overload protection and disconnect as required.
- 2 Actuators may be connected in parallel if not mechanically mounted to the same shaft. Power consumption and input impedance must be observed.
- 3 Actuators may also be powered by 24 VDC.
- 4 Position feedback cannot be used with Triac sink controller. The actuator internal common reference is not compatible.
- 5 Control signal may be pulsed from either the Hot (source) or the Common (sink) 24 VAC line.
- 7 Contact closures A & B also can be triacs. A& B should both be closed for triac source and open for triac sink.
- 8 For triac sink the common connection from the actuator must be connected to the hot connection of the controller.

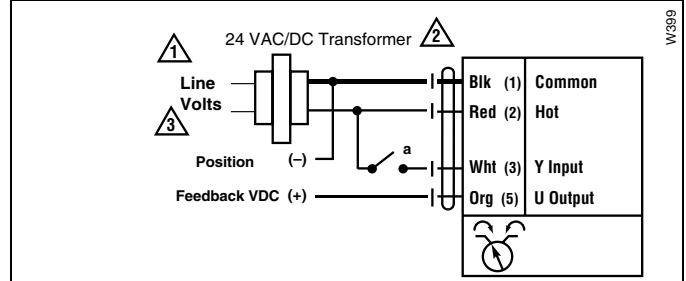

On/Off Control

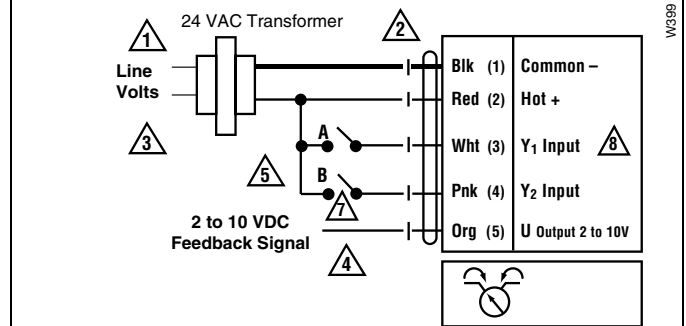

Floating Point

### Wiring Diagrams for Multiple On/Off, Floating Point Actuators

- 1 Provide overload protection and disconnect as required.
- 2 Actuators may be connected in parallel. Power consumption and input impedance must be observed.
- 3 Actuators may also be powered by 24 VDC.
- 4 Set reversing switch (CCW-CW) (A-B) as required by control logic and control range..

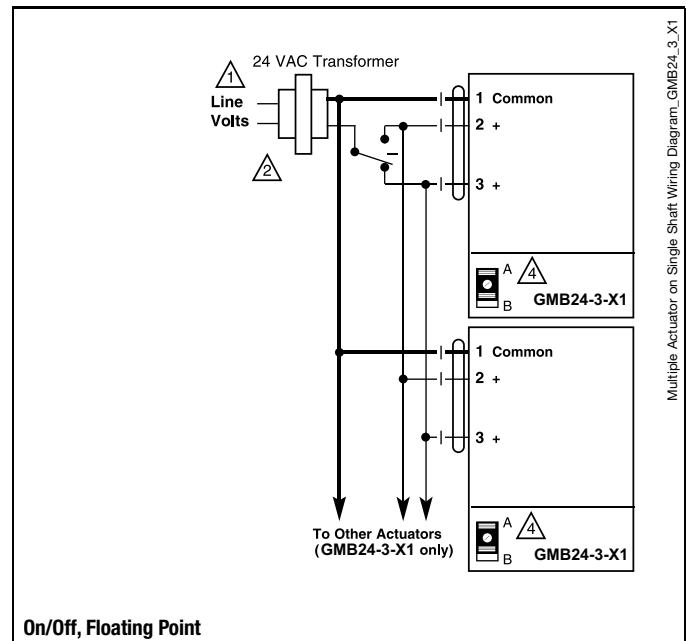

On/Off, Floating Point

	Non-Spring Return				Spring Return					Electronic Fail-Safe
	NV	NVG	GM	2 x GM	NVF	AF	2x AF	AFX	2 x AFX	GK
<b>2-way ANSI 125</b>										
G665, G665S		62	113	150		36	59	51	82	113
G680, G680S		42	78	121		24	40	34	56	78
<b>2-way Pressure Comp</b>										
G665C, G665CS, G665LCS	150				150	150		150		
G680C, G680CS, G680LCS	150				136	150		150		
G6100C, G6100CS, G6100LCS			150				132		150	150
G6125C, G6125CS, G6125LCS			150				87		150	150
G6150C, G6150CS, G6150LCS			150				50		150	150
<b>2-way ANSI 250</b>										
G665-250, G665S-250		62	113	176		36	59	51	82	113
G680-250, G680S-250		42	78	121		24	40	34	56	78
<b>3-way ANSI 125 Mixing</b>										
G765, G765S		62	113	150		36	59	51	82	114
G780, G780S		42	78	121		24	40	34	56	78
G7100, G7100S			19	31					13	19
G7125, G7125S				19						
G7150, G7150S				13						
<b>3-way ANSI 250 Mixing</b>										
G765-250, G765S-250		62	113	176		35	58	40	114	114
G780-250, G780S-250		42	78	121		23	40	25	77	78
G7100-250, G7100S-250				31					24	19
G7125-250, G7125S-250				19						
G7150-250, G7150S-250				13						
<b>3-way ANSI 125/250 Diverting</b>										
G765D, G765DS, G765DS-250		100	100			100		100		100
G780D, G780DS, G780DS-250		100	100			100		100		100
G7100D, G7100DS, G7100DS-250		100	100			100		100		100
G7125D, G7125DS, G7125DS-250			100				100		100	100
G7150D, G7150DS, G7150DS-250			100				100		100	100

M40026 - 07/10 - Subject to change. © Belimo Aircontrols (USA), Inc.