



Technical Data

	G7...-250	G7...S-250
Service	chilled or hot water, 60% glycol	chilled or hot water, 60% glycol
Flow characteristic	linear	
Action	stem up - open A to AB	
Sizes	2½" to 6"	
End fitting	250 lb. flanged	
Materials		
Body	iron	iron
Seat	bronze	stainless steel
Stem	stainless steel	stainless steel
Plug	bronze	stainless steel
Packing	NLP (no lip packing)	TFE V-ring
ANSI class	ANSI 250	
Leakage	Class III	
Max inlet Water	250 psi (1724kPa) @ 350°F	250 psi (1724kPa) @ 350°F
Media temperature Water	32°F to 350°F (0°C to 176°C)	32°F to 350°F (0°C to 176°C)
Maximum ΔP* Water	25 psi (172kPa)	50 psi (340kPa)
Rangeability	50:1	
Valve weights	G765(S)-250 G780(S)-250 G7100(S)-250 G7125(S)-250 G7150(S)-250	73 lbs 94 lbs 157 lbs 211 lbs 283 lbs

* (50% or more open)

G7...(S)-250 3-way Flow Patterns

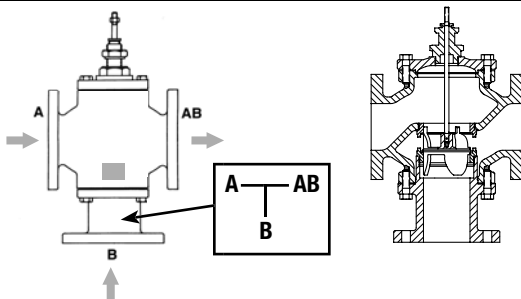

Flow Pattern is marked on valve.

Stem Up = Open B to AB

Application

This valve is typically used in Large Air Handling Units on heating or cooling coils. This valve is suitable for use in a hydronic system with variable flow.

Valves are designed for ANSI 250 piping systems.

C _v	Valve Nominal Size		Suitable Actuators			
	Inches	Type	Non-Spring	Spring	Electronic Fail-Safe	
68	2½	G765(S)-250	NVG	AF	GK Series	
91	3	G780(S)-250				
190	4	G7100(S)-250	GM Series	AFX Series	GK Series	
280	5	G7125(S)-250				
340	6	G7150(S)-250				

Dimensions

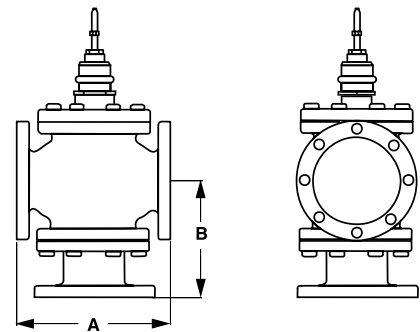

Valve Body	Valve Nominal Size		Dimensions (Inches [mm])	
	Inches	DN [mm]	A	B
G765(S)-250	2½"	[65]	9.63" [245]	7.38" [188]
G780(S)-250	3"	[80]	10.75" [273]	8.38" [213]
G7100(S)-250	4"	[100]	13.63" [346]	10.25" [260]
G7125(S)-250	5"	[125]	16.63" [422]	10.38" [264]
G7150(S)-250	6"	[150]	18.63" [473]	11.00" [279]

Piping

The valves should be mounted in a weather-protected area in a location that is within the ambient limits of the actuator. Allow sufficient room for valve with actuator and for service. For the NV Series, allow 6" for cover removal and 12" for complete actuator removal. The G6/G7 preferred mounting position of the valve is with the valve stem vertical above the valve body, for maximum life. However, the assemblies can be mounted with valve stem vertical above the valve or up to 45 degrees in relation to the horizontal pipe. The actuators should never be mounted underneath the valve, as condensation can build up and result in a failure of the actuators. Do not reverse flow direction.



Dimensions with G6/G6C ANSI 125 and G6 ANSI 250 Series 2-Way Valve

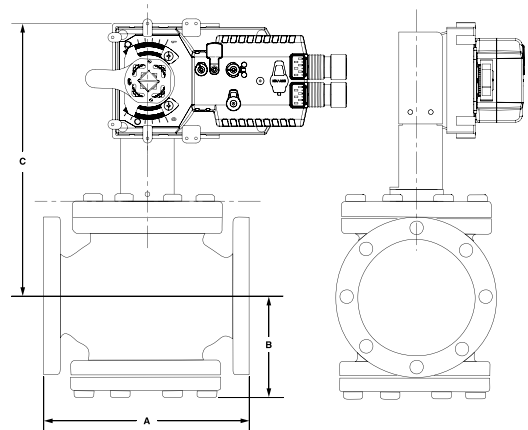

Models

GKB24-3-X1

Technical Data	
Power supply	24VAC \pm 20% 50/60Hz 24VDC \pm 10%
Power consumption	12 W (3 W)
Transformer sizing	21 VA (Class 2 power source)
Electrical connection	18 GA plenum rated cable $\frac{1}{2}$ " conduit connector protected NEMA 2 (IP54)
Overload protection	electronic throughout 0 to 95 rotation
Operation range Y	on/off, floating point
Input impedance	100 k Ω (0.1 mA), 500 Ω 1500 Ω (PWM, floating point, on/off)
Feedback output U	2 to 10VDC, 0.5mA max VDC variable
Angle of rotation	max. 95°, adjustable with mechanical stop electronically variable
Torque	360 in-lb [40Nm]
Direction of rotation	reversible with switch
Fail-safe position	adjustable with dial or tool, 0 to 100% in 10% increments
Position indication	reflective visual indicator (snap-on)
Manual override	external push button
Running time normal operation	150 seconds (default), variable 95 to 150 seconds
Running time fail-safe	35 seconds
Humidity	5 to 95% RH non-condensing (EN 60730-1)
Ambient temperature	-22°F to +122°F [-30°C to +50°C]
Storage temperature	-40°F to +176°F [-40°C to +80°C]
Housing	NEMA2, IP54, UL enclosure type 2
Housing material	UL94-5VA
Agency list	cULus acc. to UL 60730-1A/-2-14 CAN/CSA E60730-1:02 CE acc. to 2004/108/EEC and 2006/95/EC
Noise level	<45dB(A)
Quality standard	ISO 9001
Weight	3.85 lbs [1.75 kg]

Valve Nominal Size Dimensions (Inches [mm])

Valve Body	Inches	DN [mm]	A	B	C
G6 ANSI 125	2½"	65	9.00" [229]	4.75" [121]	13.50" [343]
G6 ANSI 125	3"	80	10.00" [254]	5.37" [136]	13.93" [355]
G6 ANSI 125	4"	100	13.00" [330]	6.37" [162]	16.00" [406]
G6 ANSI 250	2½"	65	9.62" [244]	4.75" [121]	13.50" [343]
G6 ANSI 250	3"	80	10.75" [273]	5.37" [136]	13.93" [355]
G6 ANSI 250	4"	100	13.62" [346]	6.37" [162]	16.00" [406]
G6C ANSI 125	4"	100	13.00" [330]	6.87" [175]	15.50" [394]
G6C ANSI 125	5"	125	15.75" [400]	7.87" [200]	16.12" [410]
G6C ANSI 125	6"	150	17.75" [451]	8.50" [216]	16.75" [425]

Dimensions with G7 and G7D ANSI 125/250 Series 3-Way Valve

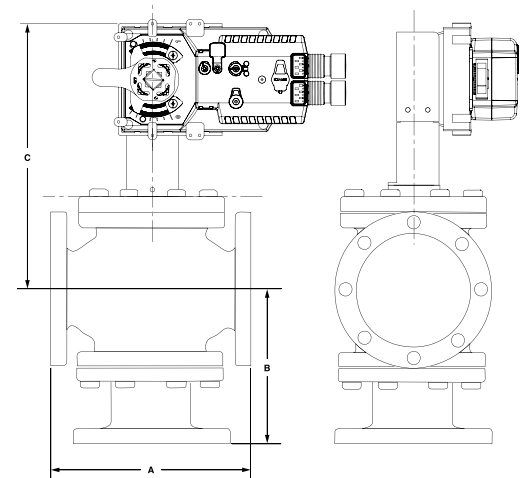

Valve Nominal Size Dimensions (Inches [mm])

Valve Body	Inches	DN [mm]	A	B	C
G7 & G7D ANSI 125	2½"	65	9.00" [229]	7.12" [181]	13.87" [352]
G7 & G7D ANSI 125	3"	80	10.00" [254]	8.00" [203]	14.43" [367]
G7 & G7D ANSI 125	4"	100	13.00" [330]	9.87" [251]	15.50" [394]
G7D ANSI 125	5"	125	12.00" [305]	10.50" [267]	14.12" [359]
G7D ANSI 125	6"	150	14.12" [359]	11.12" [283]	15.12" [505]
G7 & G7D ANSI 250	2½"	65	9.62" [244]	7.37" [187]	13.87" [352]
G7 & G7D ANSI 250	3"	80	10.75" [273]	8.37" [213]	14.43" [367]
G7 & G7D ANSI 250	4"	100	13.62" [346]	10.25" [260]	15.50" [394]
G7D ANSI 250	5"	125	12.87" [327]	11.00" [279]	14.12" [359]
G7D ANSI 250	6"	150	14.50" [368]	11.50" [292]	15.12" [505]

Wiring Diagrams

INSTALLATION NOTES

- 1 Provide overload protection and disconnect as required.
- 2 **CAUTION Equipment Damage!**
Actuators may be connected in parallel if not mechanically mounted to the same shaft. Power consumption and input impedance must be observed.
- 4 Position feedback cannot be used with Triac sink controller. The actuator internal common reference is not compatible.
- 5 Control signal may be pulsed from either the Hot (source) or the Common (sink) 24 VAC line.
- 8 Contact closures A & B also can be triacs. A & B should both be closed for triac source and open for triac sink.

APPLICATION NOTES

- Meets UL requirements without the need of an electrical ground connection.
- WARNING Live Electrical Components!**
During installation, testing, servicing and troubleshooting of this product, it may be necessary to work with live electrical components. Have a qualified licensed electrician or other individual who has been properly trained in handling live electrical components perform these tasks. Failure to follow all electrical safety precautions when exposed to live electrical components could result in death or serious injury.

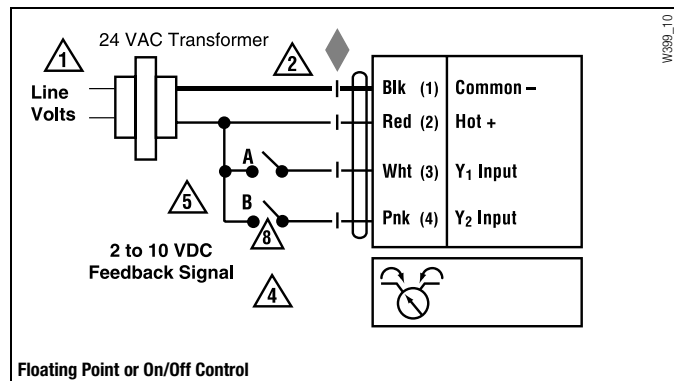

Operations

Setting the Fail-Safe Position

Belimo's new Electronic Fail-Safe Actuators allows the user to set the fail position (0-100% in 10% increments). To set the position of the fail-safe, rotate the cover away from the fail-safe switch. Turn the switch to the desired position. To set with PC Tool, turn the switch to PROG FAIL-SAFE. When done, rotate the cover back into position.

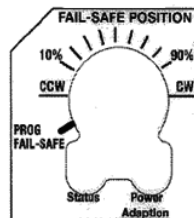

Note: If switch is left in PROG FAIL-SAFE, the PC Tool software setting is active and can set the fail-safe position. It is recommended that the switch be set on the front of the actuator. This gives a simple visual as to what the fail-safe position is set as. If the fail-safe is programmed using the PC Tool, and the switch is then moved off the PROG FAIL-SAFE position, the new position will override the PC Tool setting. The direction switch does not affect the fail-safe position switch.

	Non-Spring Return				Spring Return					Electronic Fail-Safe
	NV	NVG	GM	2 x GM	NVF	AF	2x AF	AFX	2 x AFX	GK
2-way ANSI 125										
G665, G665S		62	113	150		36	59	51	82	113
G680, G680S		42	78	121		24	40	34	56	78
G6100, G6100S			19							19
2-way Pressure Comp ANSI 125										
G665C, G665CS, G665LCS	150				150	150		150		
G680C, G680CS, G680LCS	150				136	150		150		
G6100C, G6100CS, G6100LCS			150				132		150	150
G6125C, G6125CS, G6125LCS			150				87		150	150
G6150C, G6150CS, G6150LCS			150				50		150	150
2-way Pressure Comp ANSI 250										
G665C-250, G665CS-250								250		
G680C-250, G680CS-250								250		
G6100C-250, G6100CS-250			250						212	250
G6125C-250, G6125CS-250			239						152	239
G6150C-250, G6150CS-250			178						105	178
2-way ANSI 250										
G665-250, G665S-250		62	113	176		36	59	51	82	113
G680-250, G680S-250		42	78	121		24	40	34	56	78
G6100-250, G6100S-250			19							19
3-way ANSI 125 Mixing										
G765, G765S		62	113	150		36	59	51	82	114
G780, G780S		42	78	121		24	40	34	56	78
G7100, G7100S			19	31					13	19
G7125, G7125S				19						
G7150, G7150S				13						
3-way ANSI 250 Mixing										
G765-250, G765S-250		62	113	176		35	58	40	114	114
G780-250, G780S-250		42	78	121		23	40	25	77	78
G7100-250, G7100S-250				31					24	19
G7125-250, G7125S-250				19						
G7150-250, G7150S-250				13						
3-way ANSI 125/250 Diverting										
G765D, G765DS, G765DS-250		100	100			100		100		100
G780D, G780DS, G780DS-250		100	100			100		100		100
G7100D, G7100DS, G100DS-250		100	100			100		100		100
G7125D, G7125DS, G7125DS-250			100				100		100	100
G7150D, G7150DS, G7150DS-250			100				100		100	100