

EFB120-S N4, EFX120-S N4(H)

NEMA 4, On/Off, Spring Return, 100 to 240 VAC



Technical Data		EFB120-S N4, EFX120-S N4(H)
Power supply		100...240 VAC +10% / -20%, 50/60 Hz 100...125 VDC ±10%
Power consumption	running	9.5 W / heater 22 W
	holding	4.5 W
VA rating		21 VA @ 120 VAC / heater 22 VA 29 VA @ 240 VAC
Electrical connection		terminal block(s) inside junction box with knockouts
Overload protection		electronic throughout 0 to 95° rotation
Control		on/off
Torque		270 in-lb [30 Nm] minimum
Direction of rotation	spring	reversible with CW/CCW mounting
Mechanical angle of rotation		95° (adjustable with mechanical end stop, 35° to 95°)
Running time	motor	75 sec
	spring	< 20 sec @ -4°F to 122°F [-20°C to 50°C]; < 60 sec @ -22°F [-30°C]
	spring (w/heater)	< 20 sec @ -22°F to 122°F [-30°C to 50°C]; < 60 sec @ -40°F [-40°C]
Position indication		visual indicator, 0° to 95° (0° is full spring return position)
Manual override		5 mm hex crank (3/16" Allen), supplied
Humidity		max. 95% RH non-condensing
Ambient temperature		-22°F to 122°F [-30°C to 50°C]
	with heater	-40°F to 122°F [-40°C to 50°C]
Storage temperature		-40°F to 176°F [-40°C to 80°C]
Housing		NEMA 4, IP66, Enclosure Type4
Housing material		aluminum diecast and plastic casing
Agency listings †		cULus acc. to UL60730-1A/-2-14, CAN/CSA E60730-1:02, CE acc. to 2004/108/EC & 2006/95/EC
Noise level		≤56.5dB(A) motor @ 75 seconds ≤71.4dB(A) spring return
Servicing		maintenance free
Quality standard		ISO 9001
Weight		10 lbs [4.54 kg], 10.1 lbs [4.59 kg] with heater
† Rated Impulse Voltage 2.5kV, Type of action 1.AA (1.AA.B for -S version), Control Pollution Degree 4. EFX120-S N4H is only UL listed.		
EFB120-S N4, EFX120-S N4(H)		
Auxiliary switches		2 x SPDT 3A (0.5A) @ 250 VAC, UL Approved one set at 10° and one set at 85°

Torque min. 270 in-lb, for control of air dampers

Application

For on/off, fail-safe control of dampers in HVAC systems. Actuator sizing should be done in accordance with the damper manufacturer's specifications. Control is On/Off from an auxiliary contact, or a manual switch.

The actuator is mounted directly to a damper shaft up to 1.05" in diameter by means of its universal clamp. A crank arm and several mounting brackets are available for applications where the actuator cannot be direct coupled to the damper shaft.

Operation

The EFB N4 and EFX N4 series actuators provide true spring return operation for reliable fail-safe application and positive close off on air tight dampers. The spring return system provides constant torque to the damper with, and without, power applied to the actuator.

The EFB N4 and EFX N4 series provides 95° of rotation and is provided with a graduated position indicator showing 0° to 95°.

The actuator may be stalled anywhere in its normal rotation without the need of mechanical end switches.

The EFB120-S N4 and EFX120-S N4(H) versions are provided with two built-in auxiliary switches. These SPDT switches provide safety interfacing or signaling, for example, for fan start-up. The switching function at the fail-safe position is fixed at +10°, the other switch function is fixed at 85°. The EFB120-S N4 and EFX120-S N4(H) actuator is shipped at +5° (5° from full fail-safe) to provide automatic compression against damper gaskets for tight shut-off.

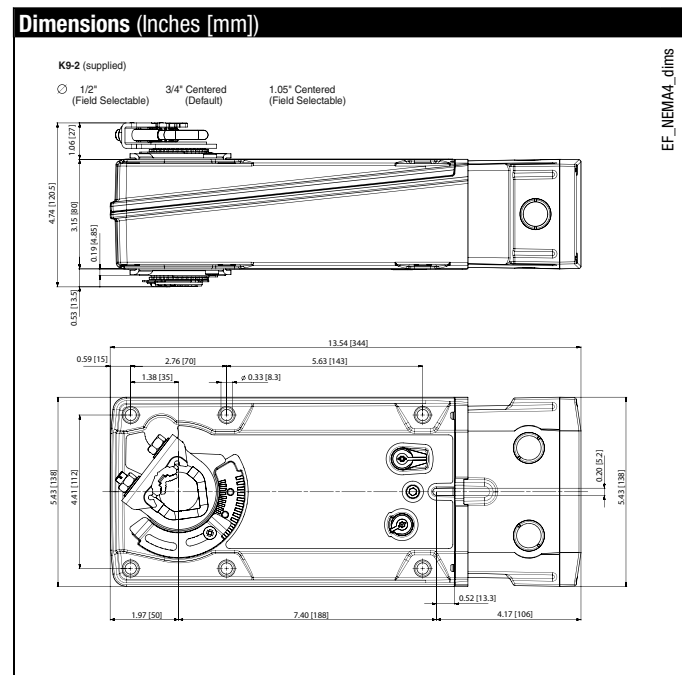

M40103 - 09/11 - Subject to change. © Belimo Aircontrols (USA), Inc.

Accessories

IND-EFB	Damper position indicator
KH-EFB	Crank arm
K9-2	Universal clamp for up to 1.05" diameter jackshafts
Tool-07	13 mm wrench
ZG-EFB	Crank arm adaptor kit

Note: When using EFB120-S N4, EFX120-S N4(H) actuators, only use accessories listed on this page.

For actuator wiring information and diagrams, refer to Belimo Wiring Guide.

Typical Specification

On/Off spring return damper actuators shall be direct coupled type which require no crank arm and linkage and be capable of direct mounting to a jackshaft up to a 1.05" diameter. The actuators must be designed so that they may be used for either clockwise or counterclockwise fail-safe operation. Actuators shall be protected from overload at all angles of rotation. If required, two SPDT auxiliary switch shall be provided. Actuators with auxiliary switches must be constructed to meet the requirements for Double Insulation so an electrical ground is not required to meet agency listings. Actuators shall be cULus approved and have a 5 year warranty, and be manufactured under ISO 9001 International Quality Control Standards. Actuators shall be as manufactured by Belimo.

Wiring Diagrams

✂️ INSTALLATION NOTES

- 1 Provide overload protection and disconnect as required.
- 2 **CAUTION Equipment Damage!**
Actuators may be connected in parallel.
Power consumption and input impedance must be observed.
- 3 No ground connection is required.
- 4 For end position indication, interlock control, fan startup, etc., EFB120-S N4 and EFX120-S N4(H) incorporates two built-in auxiliary switches: 2 x SPDT, 3A (0.5A) @250 VAC, UL Approved, one switch is fixed at 10°, the other is fixed at 85°.

📄 APPLICATION NOTES

- ◆ Meets cULus requirements without the need of an electrical ground connection.

⚠️ WARNING Live Electrical Components!
During installation, testing, servicing and troubleshooting of this product, it may be necessary to work with live electrical components. Have a qualified licensed electrician or other individual who has been properly trained in handling live electrical components perform these tasks. Failure to follow all electrical safety precautions when exposed to live electrical components could result in death or serious injury.

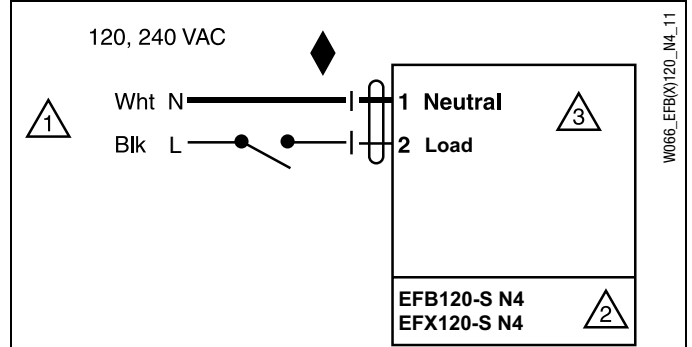

On/Off wiring

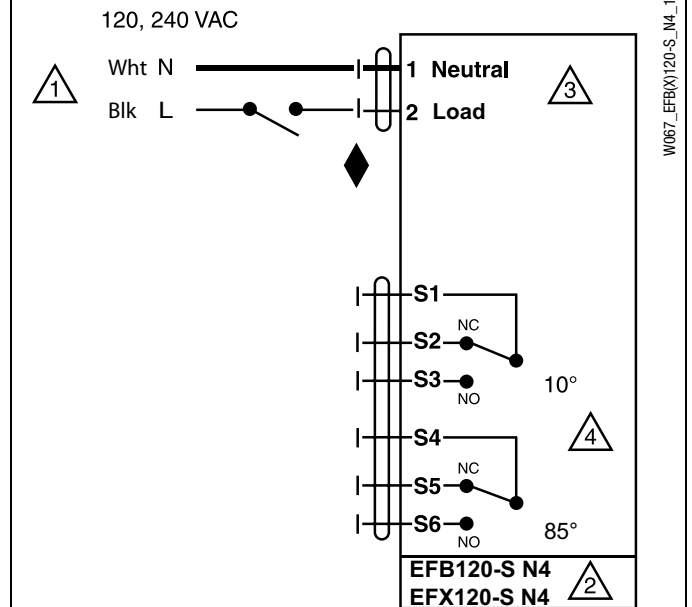

Auxiliary Switches

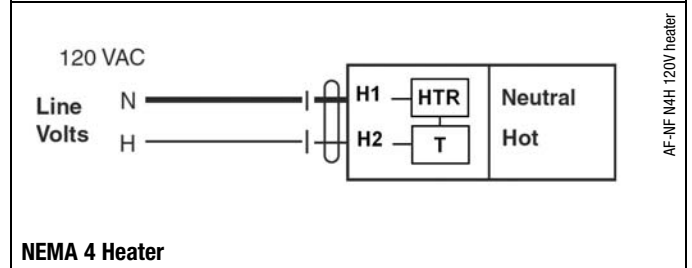

NEMA 4 Heater